

ARMY TM 9-2320-272-24-2 AIR FORCE TO 36A12-1C-1155-2-2

This publication supersedes TM 9-2320-272-20-1, October 1985, and changes 1 through 4; TM 9-2320-272-20-2, October 1985, and changes 1 through 3; TM 9-2320-272-34- 1, June 1986, and changes 1 through 2; TM 9-2320-272-34-2, June 1986, and changes 1 and 2; and TM 9-2320-358-24&P, October 1992.

TECHNICAL MANUAL VOLUME 2 OF 4

UNIT MAINTENANCE (Condt) 3-615

UNIT, DIRECT SUPPORT, AND GENERAL SUPPORT MAINTENANCE MANUAL FOR

DIRECT SUPPORT (DS) MAINTENANCE 4-1

TRUCK, 5-TON, 6X6, M939, M939A1, M939A2 SERIES TRUCKS (DIESEL)

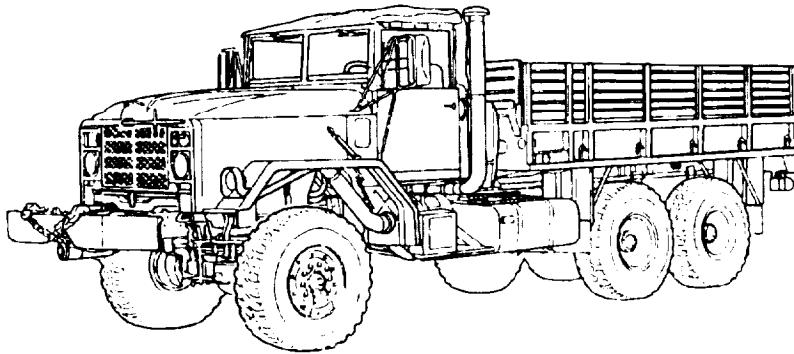

TRUCK, CARGO: 5-TON, 6X6, DROPSIDE,

M923 (2320-01-050-2084) (EIC: BRY); M923A1 (2320-01-206-4087) (EIC: BSS); M923A2 (2320-01-230-0307) (EIC: BS7);
M925 (2320-01-047-8769) (EIC: BRT); M925A1 (2320-01-206-4088) (EIC: BST); M925A2 (2320-01-230-0308) (EIC: BS8);

TRUCK, CARGO: 5-TON, 6X6 XLWB,

M927 (2320-01-047-8771) (EIC: BRV); M927A1 (2320-01-206-4089) (EIC: BSW); M927A2 (2320-01-230-0309) (EIC: BS9);
M928 (2320-01-047-8770) (EIC: BRU); M928A1 (2320-01-206-4090) (EIC: BSX); M928A2 (2320-01-230-0310) (EIC: BTM);

TRUCK, DUMP: 5-TON, 6X6,

M929 (2320-01447-8756) (EIC: BTH); M929A1 (2320-01-206-4079) (EIC: BSY); M929A2 (2320-01-230-0305) (EIC: BTN);
M930 (2320-01-047-8755) (EIC: BTG); M930A1 (2320-01-206-4080) (EIC: BSZ); M930A2 (2320-01-230-0306) (EIC: BTO);

TRUCK, TRACTOR: 5-TON, 6X6,

M931 (2320-01-047-8753) (EIC: BTE); M931A1 (2320-01-206-4077) (EIC: BS2); M931A2 (2320-01-230-0302) (EIC: BTP);
M932 (2320-01-047-8752) (EIC: BTD); M932A1 (2320-01-205-2684) (EIC: BS5); M932A2 (2320-01-230-0303) (EIC: BTQ);

TRUCK, VAN, EXPANSIBLE: 5-TON, 6X6,

M934 (2320-01-047-8750) (EIC: BTB); M934A1 (2320-01-205-2682) (EIC: BS4); M934A2 (2320-01-230-0300) (EIC: BTR);

TRUCK, MEDIUM WRECKER: 5-TON, 6X6,

M936 (2320-01-047-8754) (EIC: BTF); M936A1 (2320-01-206-4078) (EIC: BS6); M936A2 (2320-01-230-0304) (EIC: BTT).

DISTRIBUTION STATEMENT A - Approved for public release; distribution is unlimited.

DEPARTMENTS OF THE ARMY AND THE AIR FORCE

JUNE 1998

WARNING**EXHAUST GASES CAN KILL**

1. DO NOT operate vehicle engine in enclosed area.
 2. DO NOT idle vehicle engine with windows closed.
 3. DO NOT drive vehicle with inspection plates or cover plates removed.
 4. BE ALERT at all times for odors.
 5. BE ALERT for exhaust poisoning symptoms. They are:
 - Headache
 - Dizziness
 - Sleepiness
 - Loss of muscular control
 6. IF YOU SEE another person with exhaust poisoning symptoms:
 - Remove person from area
 - Expose to open air
 - Keep person warm
 - Do not permit person to move
 - Administer artificial respiration or CPR, if necessary*

*For artificial respiration, refer to FM 21-11.
 7. BE AWARE: The field protective mask for Nuclear, Biological, or Chemical (NBC) protection will not protect you from carbon monoxide poisoning.
- THE BEST DEFENSE AGAINST EXHAUST POISONING IS ADEQUATE VENTILATION.**

WARNING SUMMARY

- Hearing protection is required for the driver and passenger. Hearing protection is also required for all personnel working in and around this vehicle while the engine is running (AR-40-5 and TB MED 501).
- If required to remain inside vehicle during extreme heat, occupants should follow the water intake, work/rest cycle, and other stress preventive measures (FM 21-10, Field Hygiene and Sanitation).
- If NBC exposure is suspected, all air filter media should be handled by personnel wearing protective equipment. Consult with your unit NBC officer or NBC NCO for appropriate handling or disposal instructions.
- This vehicle has been designed to operate safely and efficiently within the limits specified in this TM. Operation beyond these limits is prohibited by IAW AR 70-1 without written approval from the commander, U.S. Army Tank-automotive and Armaments Command, ATTN: AMCPEO-CM-S, Warren, MI 48397-5000.
- Never work under dump body unless safety braces are properly positioned. Failure to do this will result in injury to personnel.
- During winching operation, never stand between vehicles. Assistant must remain in secondary vehicle to engage service brake if cable snaps or automatic brake fails while towing vehicle. Failure to do this may result in injury to personnel.
- Accidental or intentional introduction of liquid contaminants into the environment is in violation of state, federal, and military regulations. Refer to Army POL (para. I-7) for information concerning storage, use, and disposal of these liquids. Failure to do so may result in injury or death.
- Cleaning solvents are flammable and toxic. Do not use near open flame and always have a fire extinguisher nearby when solvents are used. Use only in well-ventilated places, wear protective clothing, and dispose of cleaning rags in approved container. Failure to do this will result in injury to personnel and/or damage to equipment.
- Eyeshields must be worn when cleaning with compressed air. Compressed air source will not exceed 30 psi (207 kPa). Failure to do so may result in injury to personnel.
- Extreme care should be taken when removing surge tank filler cap if temperature gauge reads above 175°F (79°C). Steam or hot coolant under pressure will cause injury.
- Alcohol used in the alcohol evaporator is flammable, poisonous, and explosive. Do not smoke when removing alcohol evaporator or adding fluid, and do not drink fluid. Failure to do this will result in injury or death.
- Do not perform electrical circuit testing fuel tank with fill cap or sending unit removed. Fuel may ignite, causing injury to personnel.
- When performing battery maintenance, ensure batteries are seated and clamped down, all rubber boots are installed, clamps are well down on battery posts, and all battery cables lie flat against the top of the batteries. Failure to do this may result in injury to personnel and/or damage to equipment.
- Ensure companion seatbelts are not caught inside battery box. This will cause belts to rot which may lead to injury of personnel.
- On M936/A1/A2 model vehicles, remove spare tire prior to changing tire and install tire in spare tire carrier after tire change is complete. Operation of crane and/or vehicle engine while vehicle is on jacks may result in injury to personnel or damage to equipment.
- Never assemble or disassemble tire and rim assembly while inflated, use inflation to seat locking on split rim or tire on two-piece rim, or inflate a tire without a tire inflation cage. Injury to personnel may result.
- Do not disconnect air lines or hoses, remove safety valves or CTIS components, or perform brake chamber repairs before draining air reservoirs. Small parts under pressure may shoot out with high velocity, causing injury to personnel.

Warning b

WARNING SUMMARY (Contd)

- Remove all jewelry when working on electrical circuits. Jewelry coming in contact with electrical circuits may produce a short circuit, causing extreme heat, explosions, and fling particles of metal. Failure to do so will result in injury or death and damage to equipment.
- Use eyeshields and follow instructions carefully when performing assembling, disassembling, or maintenance on this device. Components of this device are under spring tension and may shoot out at a high velocity. Failure to do so will result in injury to personnel.
- Do not remove hoses with engine running or start engine with hoses removed. High-pressure fluids may cause hoses to whip violently and spray randomly. Failure to do so may result in injury to personnel.
- Keep hands out from between metal surfaces when removing heavy components. Failure to do so may result in injury to personnel.
- Keep personnel out from under equipment and components of equipment when supported by only a lifting device. Sudden loss of lifting power or shift in load may result in injury or death.
- Do not drain engine, transmission, or radiator fluids, or remove lines containing these fluids, when hot. Doing so may result in injury to personnel.
- Vehicle will become charged with electricity if it contacts or breaks high-voltage wires. Do not leave vehicle while high-voltage lines are in contact with vehicle. Failure to do so may result in injury to personnel.
- Wear hand protection when handling lifting and winching cables, hot exhaust components, and parts with sharp edges. Failure to do so may result in injury to personnel.
- Do not perform fuel system procedures while smoking or within 50 ft (15.2 m) of sparks or open flame. Diesel fuel is highly flammable and can explode easily, causing injury or death to personnel and/or damage to equipment.
- Ensure drainvalve on aftercooler is open when filling cooling system. Failure to do so may result in injury to personnel.
- Turbocharger intake fins are extremely sharp and turn at very high rpm. Keep hands and loose items away from intake openings. Failure to do so may result in injury to personnel.
- Do not place hands between frame and radiator when removing screws from trunnion or lifting radiator. Sudden changes in support may cause the radiator to shift, causing injury to personnel.
- Air pressure may create airborne debris. Use eye protection or injury to personnel may result.
- Air system components are subject to high pressure. Always relieve pressure before loosening or removing air system components.
- Wear safety goggles when using a hammer.
- Ether is extremely flammable. Do not perform ether start system procedures near fire. Injury to personnel may result.

Warning c/(Warning d blank)

TECHNICAL, MANUAL
NO. 9-2320-272-24-2

HEADQUARTERS
DEPARTMENTS OF THE ARMY AND THE AIR FORCE
Washington, D.C., 30 JUNE 1998

TECHNICAL ORDER
NO. 36A12-1C-1155-2-2

TECHNICAL MANUAL
VOLUME 2 OF 4
UNIT, DIRECT SUPPORT, AND
GENERAL SUPPORT MAINTENANCE MANUAL
FOR

TRUCK, 5-TON, 6X6, M939, M939A1, M939A2 SERIES TRUCKS (DIESEL)

TRUCK	MODEL	EIC	NSN WITHOUT WINCH	NSN WITH WINCH
Cargo, Dropside	M923	BR Y	2320-01-050-2084	
Cargo, Dropside	M923A1	BSS	2320-01-206-4087	
Cargo, Dropside	M923A2	BS7	2320-01-230-0307	
Cargo, Dropside	M925	BRT		2320-01-047-8769
Cargo, Dropside	M925A1	BST		2320-01-206-4088
Cargo, Dropside	M925A2	BS8		2320-01-230-0308
Cargo	M927	BRV	2320-01-047-8771	
Cargo	M927A1	BSW	2320-01-206-4089	
Cargo	M927A2	BS9	2320-01-230-0309	
Cargo	M928	BRU		2320-01-047-8770
Cargo	M928A1	BSX		2320-01-206-4090
Cargo	M928A2	BTM		2320-01-230-0310
Dump	M929	BTH	2320-01-047-8756	
Dump	M929A1	BSY	2320-01-206-4079	
Dump	M929A2	BTN	2320-01-230-0305	
Dump	M930	BTG		2320-01-047-8755
Dump	M930A1	BSZ		2320-01-206-4080
Dump	M930A2	BTO		2320-01-230-0306
Tractor	M931	BTE	2320-01-047-8753	
Tractor	M931A1	BS2	2320-01-206-4077	
Tractor	M931A2	BTP	2320-01-230-0302	
Tractor	M932	BTD		2320-01-047-8752
Tractor	M932A1	BS5		2320-01-205-2684
Tractor	M932A2	BTQ		2320-01-230-0303
Van, Expansible	M934	BTB	2320-01-047-8750	
Van, Expansible	M934A1	BS4	2320-01-205-2682	
Van, Expansible	M934A2	BTR	2320-01-230-0300	
Medium Wrecker	M936	BTF		2320-01-047-8754
Medium Wrecker	M936A1	BS6		2320-01-206-4078
Medium Wrecker	M936A2	BTT		2320-01-230-0304

REPORTING OF ERRORS AND RECOMMENDING IMPROVEMENTS

You can help improve this manual. If you find any mistakes or if you know of a way to improve the procedures, please let us know. Mail your letter or DA Form 2028 (Recommended Changes to Publications and Blank Forms), or DA Form 2028-2 located in back of this manual, directly to: Director, Armament and Chemical Acquisition and Logistics Activity, ATTN: AMSTA-AC-NML, Rock Island, IL 61299-7630. A reply will be furnished to you. You may also provide DA Form 2028-2 information via datafax or e-mail:

- E-mail: amsta-ac-nml. @ria-emh2.army.mil
- Fax: DSN 783-0726 or commercial (309) 782-0726

DISTRIBUTION STATEMENT A - Approved for public release; distribution is unlimited.

*This publication supersedes TM 9-2320-272-20-1, 24 October 1985, and changes 1 through 4; TM 9-2320-272-20-2, 25 October 1985, and changes 1 through 3; TM 9-2320-272-34-1, 10 June 1986, and changes 1 through 2; TM 9-2320-272-34-2 10 June 1986, and changes 1 and 2; and TM 9-2320-358-24&P, 21 October 1992.

This publication is published in four volumes. TM 9-2320-272-24-1 contains chapters 1, 2, and 3 (though section IX). TM 9-2320-272-24-2 contains chapters 3 (sections X through XVI) and 4 (sections I through III). TM 9-2320-272-24-3 contains chapter 4 (sections IV through XVI). TM 9-2320-272-24-4 contains chapters 5 and 6 and appendices A through H. Volume 1 contains a table of contents for the entire manual. Volumes 1, 2, and 3 contain an alphabetical index covering tasks found in their respective volume. Volume 4 contains an alphabetical index covering all tasks found in the entire manual.

TABLE OF CONTENTS

VOLUME 2 OF 4

		page
CHAPTER 3	UNIT MAINTENANCE	(Contd)
Section X	Wheels, Hubs, Drums, and Steering Maintenance	3-615
Section XI.	Frame Maintenance	3-683
Section XII.	Body, Cab, and Accessories Maintenance	3-730
Section XIII.	Winch and Power Takeoff (FTO) Maintenance	3-823
Section XIV	Special Purpose Bodies Maintenance	3-869
Section XV	Special Purpose Kits	3-972
Section XVI.	Central Tire Inflation System (CTIS) Maintenance	3-1235
CHAPTER 4	DIRECT SUPPORT (DS) MAINTENANCE	4-1
Section I.	Direct Support (DS) and General Support (GS) Mechanical Troubleshooting	4-1
Section II.	Power Plant Maintenance	4-35
Section III.	Engine (M939/A1) Maintenance	4-117

Section X. WHEELS, HUBS, DRUMS, AND STEERING MAINTENANCE

3-217. WHEELS, HUBS, DRUMS, AND STEERING MAINTENANCE INDEX

PARA. NO.	TITLE	PAGE NO.
3-218.	Wheel and Tire (M939) Rotation	3-616
3-219.	Wheel and Tire (M939A1/A2) Rotation	3-622
3-220.	Tire and Tube (M939) Maintenance	3-626
3-221.	Tire and Wheel (M939A1/A2) Maintenance	3-630
3-222.	Wheel Rim Stud Replacement	3-636
3-223.	Front Hub and Drum (M939/A1) Maintenance	3-638
3-224.	Rear Hub and Drum (M939/A1) Maintenance	3-642
3-225.	Wheel Bearing Adjustment	3-648
3-226.	Steering Wheel Replacement	3-651
3-227.	Pitman Arm Replacement (Ross)	3-653
3-228.	Pitman Arm Replacement (Sheppard)	3-654
3-229.	Drag Link Replacement	3-655
3-230.	Steering Pump Drivebelts (M939/A1) Maintenance	3-656
3-231.	Steering Assist Cylinder Stone Shield Replacement	3-658
3-232.	Steering Assist Cylinder Hoses Replacement	3-660
3-233.	Steering Assist Cylinder Maintenance	3-662
3-234.	Power Steering Pump Pressure and Return Hoses Replacement (Ross)	3-668
3-235.	Power Steering Pump Pressure and Return Hoses Replacement (Sheppard)	3-670
3-236.	Power Steering Pump Maintenance	3-672
3-237.	Power Steering Pump Filter and Reservoir (M939A2) Maintenance	3-674
3-238.	Steering Gear Stone Shield Replacement	3-676
3-239.	Steering Gear-to-Assist Cylinder Pressure Lines Replacement	3-678

3-218. WHEEL AND TIRE (M939) ROTATION

THIS TASK COVERS:

- | | |
|---|--|
| <p>a. Wheel and Tire Removal
 b. Inspection
 c. Wheel and Tire Rotation</p> | <p>d. Inner Rear Wheel Installation
 e. Outer Rear Wheel Installation
 f. Front Wheel Installation</p> |
|---|--|

INITIAL SETUP:

APPLICABLE MODELS

M939

SPECIAL TOOLS

Inner wheel socket (Appendix E, Item 77)

TOOLS

General mechanic's tool kit (Appendix E, Item 1)
 Torque wrench (Appendix E, Item 145)
 Torque multiplier

REFERENCES (TM)

TM 9-2320-272-10
 TM 9-2320-272-24P
 TM 9-2610-200-24

EQUIPMENT CONDITION

- Parking brake set (TM 9-2320-272-10).
- Spare tire removed (TM 9-2320-272-10).

GENERAL SAFETY INSTRUCTIONS

Ensure inner and outer lug nuts are properly torqued.

a. Wheel and Tire Removal

1. Loosen sixty stud nuts (3) on four outside rear wheels (5) and two front wheels (2).
2. Using hydraulic jack, raise vehicle and place two jack stands under rear-rear axle (6), two jack stands under forward-rear axle (4), and two jack stands under front axle (1).

NOTE

Tag wheels for rotation.

3. Remove sixty stud nuts (3), two front wheels (2), and four outside rear wheels (5) from vehicle.
4. Using inner wheel socket, remove forty inner wheel spacer nuts (7) and four inside rear wheels (8) from vehicle.

b. Inspection

1. Inspect wheel rims (9) for cracks, stud hole damage, and bends. Replace wheel rims (9), if cracked, damaged, or bent.
2. Inspect tires (10) for tread wear (TM 9-2610-200-24).

3-218. WHEEL AND TIRE (M939) ROTATION (Contd)

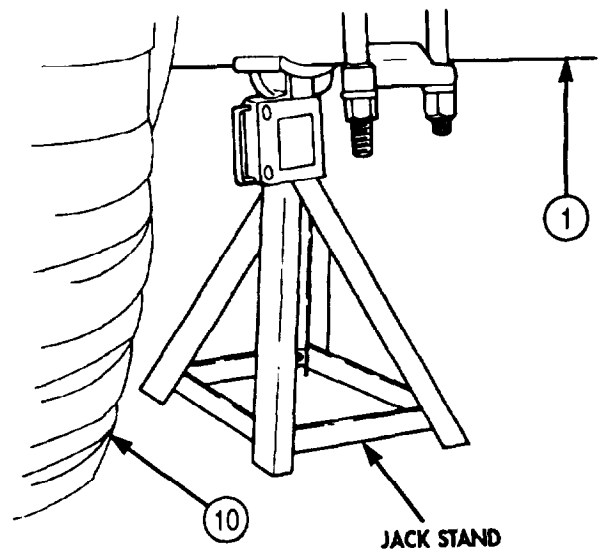
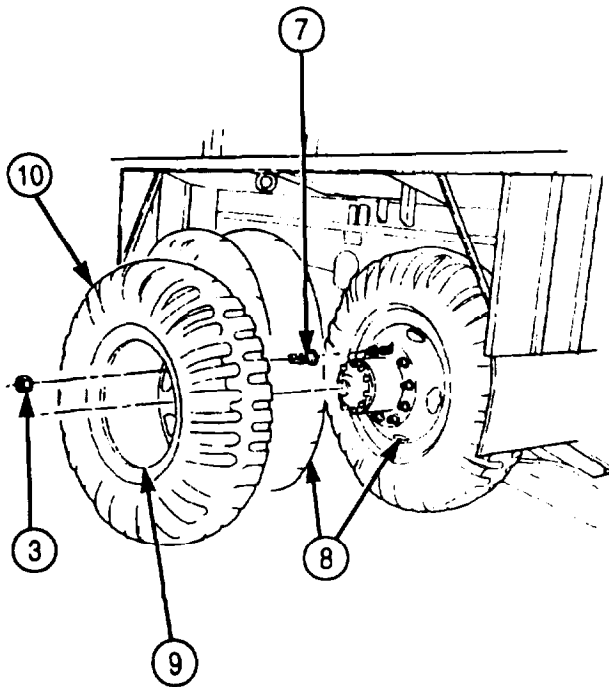
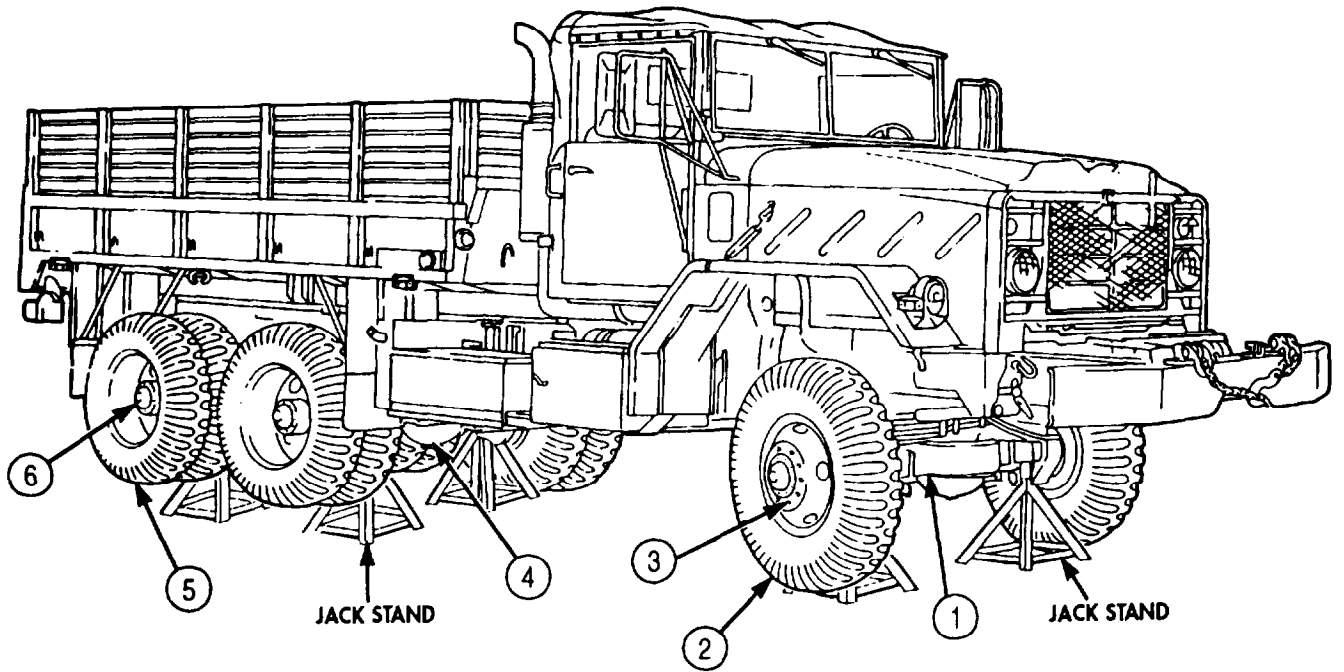

3-218. WHEEL AND TIRE (M939) ROTATION (Contd)

c. Wheel and Tire Rotation

NOTE

- Wheels and tires are rotated the same for all M939 series vehicles.
- To maintain tread depth and pattern of dual tires, tires must be rotated to match tread wear as closely as possible.
(TM 9-2610-200-24.)

Rotate wheels and tires as shown.

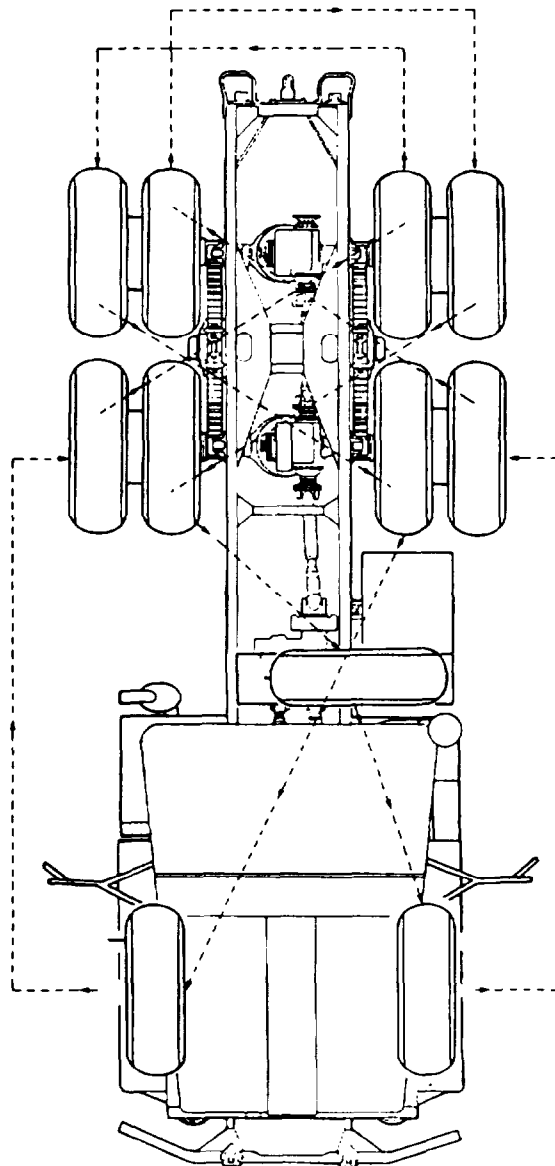

3-218. WHEEL AND TIRE (M939) ROTATION (Contd)

d. Inner Rear Wheel Installation

NOTE

- Ensure inner rear wheels are installed so valve stems to both rear wheels are accessible.
 - Start all threaded nuts by hand to prevent cross-threading. Left wheels have left-hand threaded wheel studs and right wheels have right-hand threaded wheel studs.
1. Position four rear inner dual wheels (1) over wheel hub studs (2).

WARNING

Apply proper torque to inner lug nuts. Failure to do so may result in injury to personnel or damage to equipment.

2. Using inner wheel socket, install four rear inner dual wheels (1) on wheel hub (2) with forty inner wheel spacer nuts (3).
3. Tighten spacer nuts (3) 325-355 lb-ft (441-481 N•m) in sequence shown.

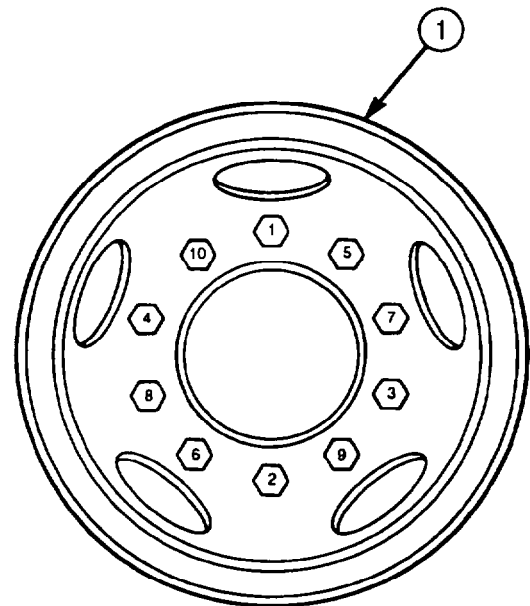
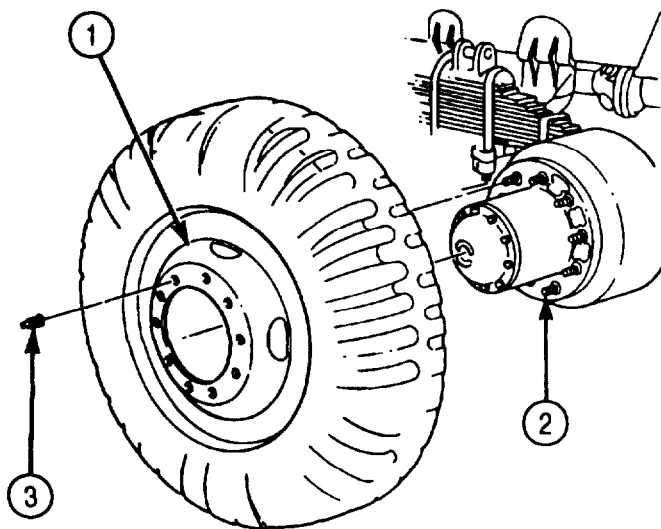

TIGHTENING SEQUENCE

3-218. WHEEL AND TIRE (M939) ROTATION (Contd)

e. Outer Rear Wheel Installation

1. Position four rear outer dual wheels (2) on wheel adapter spacer nuts (1).

WARNING

Apply proper torque to outer lug nuts. Failure to do so may result in injury to personnel or damage to equipment.

2. Install four rear outer dual wheels (2) on vehicle with forty stud nuts (3). Hand-tighten stud nuts (3).
3. Raise rear of vehicle, remove jack stands, and lower vehicle.
4. Tighten forty stud nuts (3) 325-355 lb ft (441-481 N-m) in sequence shown.

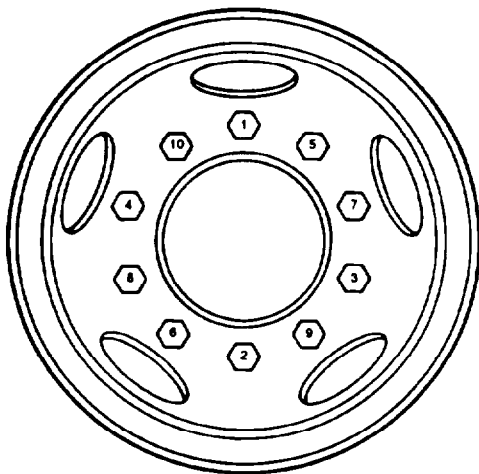
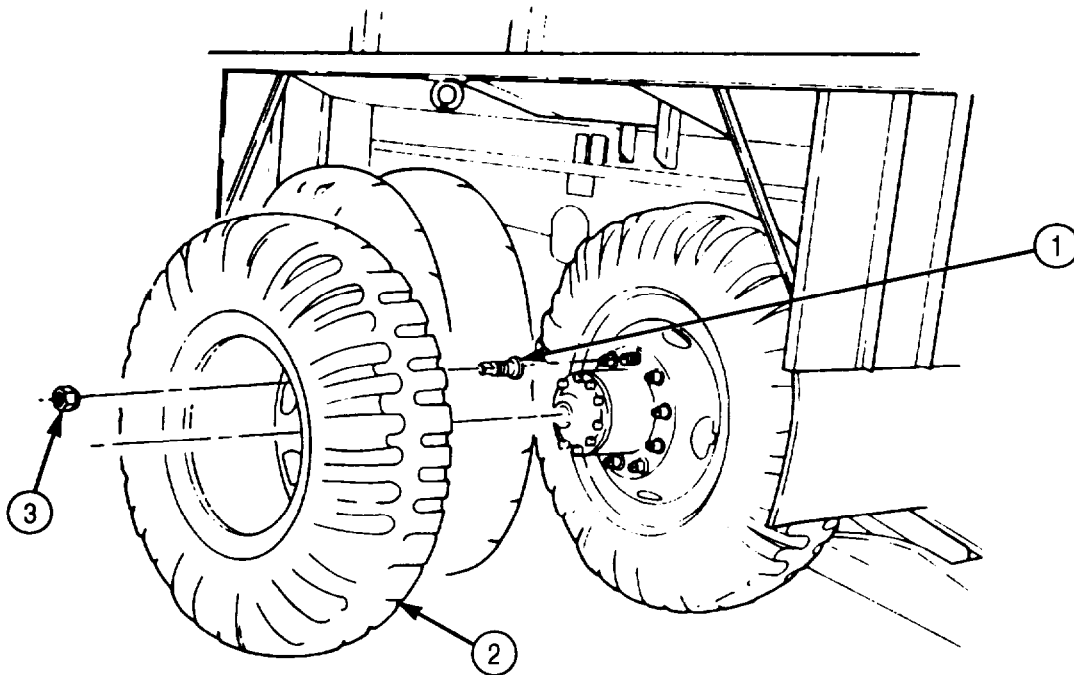

TIGHTENING SEQUENCE

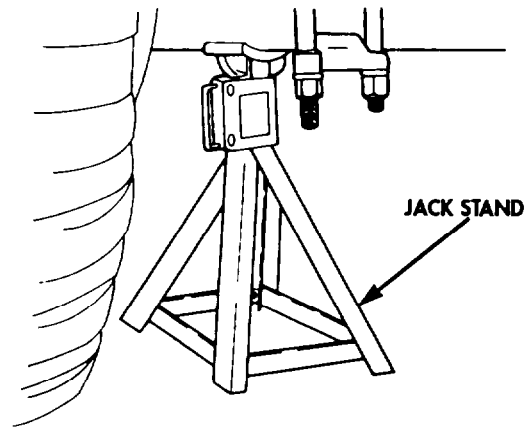

JACK STAND

3-218. WHEEL AND TIRE (M939) ROTATION (Contd)

f. Front Wheel Installation

1. Install two front wheels (5) on wheel hub studs (4) with twenty wheel stud nuts (6). Hand-tighten stud nuts (6).
2. Raise front of vehicle clear of jack stands, remove jack stands, and lower vehicle.
3. Tighten twenty wheel stud nuts (6) 325-355 lb-ft (441-481 N•m) in sequence shown.

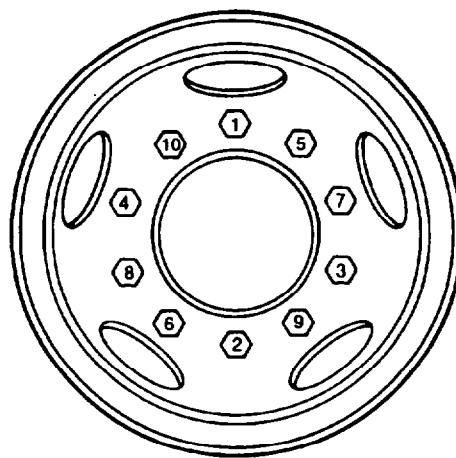
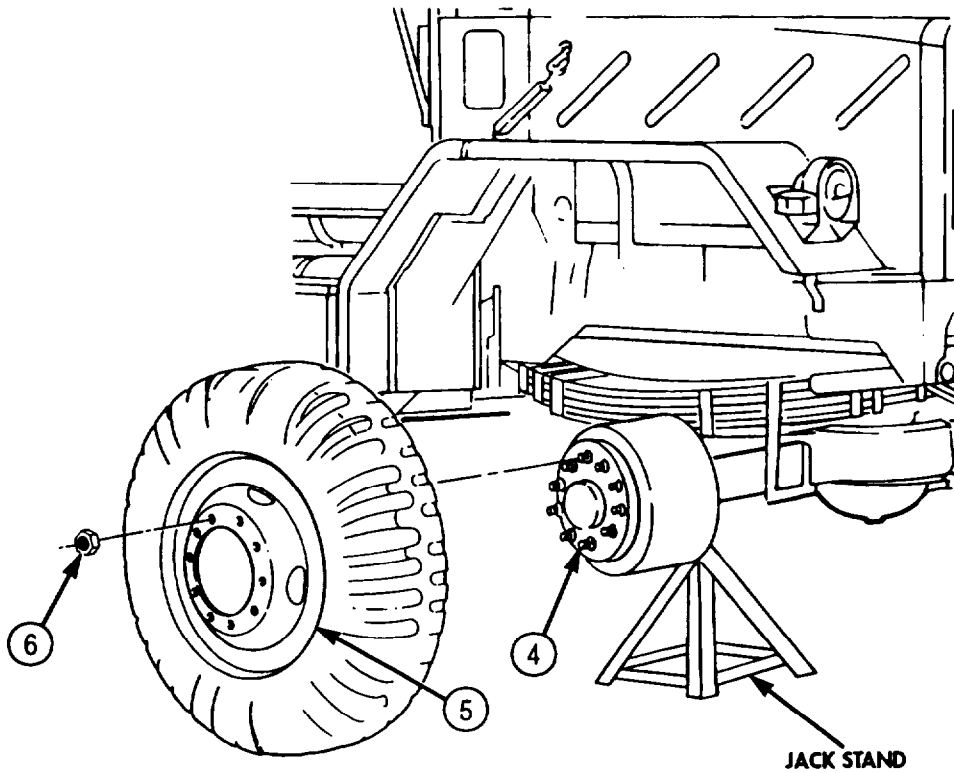

TIGHTENING SEQUENCE

3-219. WHEEL AND TIRE (M939A1/A2) ROTATION

THIS TASK COVERS:

- a. Wheel and Tire Removal
- b. Inspection
- c. Wheel and Tire Rotation
- d. Rear Wheel Installation
- e. Front Wheel Installation

INITIAL SETUP:

APPLICABLE MODELS

M939A1/A2

TOOLS

General mechanic's tool kit (Appendix E, Item 1)
Torque wrench (Appendix E, Item 145)

REFERENCES (TM)

TM 9-2320-272-10
TM 9-2320-272-24P
TM 9-2610-200-24

EQUIPMENT CONDITION

- Parking brake set (TM 9-2320-272-10).
- Front wheel valve removed (para. 3-456).
- Rear wheel valve removed (para. 3-457).

GENERAL SAFETY INSTRUCTIONS

Ensure lug nuts are properly torqued.

a. Wheel and Tire Removal

NOTE

Perform step 1 for M939A2 vehicles only.

1. Remove two nuts (6) and wheel weights (5) from two front wheels (2) and studs (4).
2. Loosen sixty stud nuts (7) on four rear wheels (1) and two front wheels (2).
3. Raise vehicle and place two jack stands under rear-rear axle, two jack stands under forward-rear axle (9), and two jack stands under front axle (3).

NOTE

Tag wheels for installation.

4. Remove sixty stud nuts (7), two front wheels (2), and four rear wheels (1) from vehicle.

b. Inspection

1. Inspect wheel rims (8) for cracks, stud hole damage, and bends. Replace wheel rims (8) if cracked, stud holes damaged or bent.
2. Inspect tires for thread wear (TM 9-2610-200-24).

3-219. WHEEL AND TIRE (M939A1/A2) ROTATION (Contd)

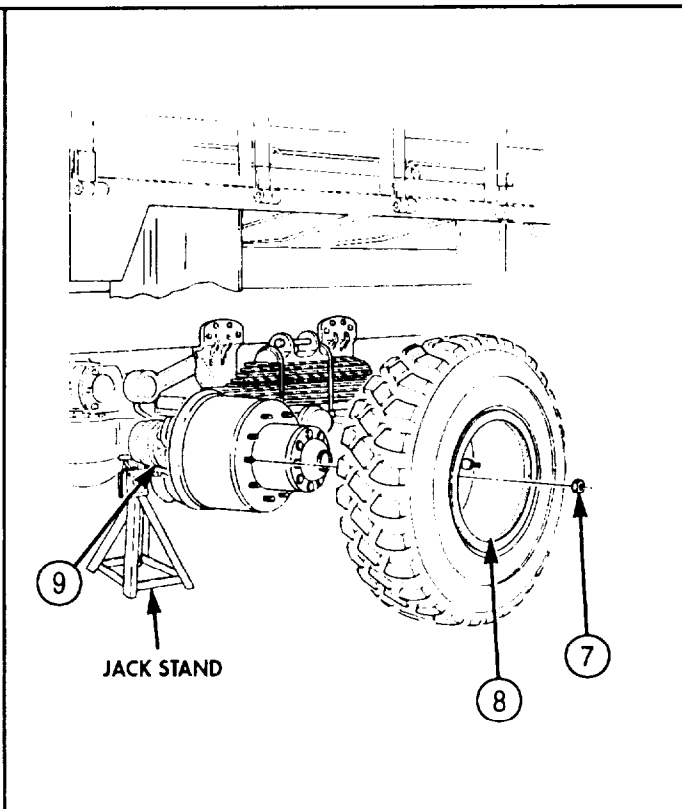
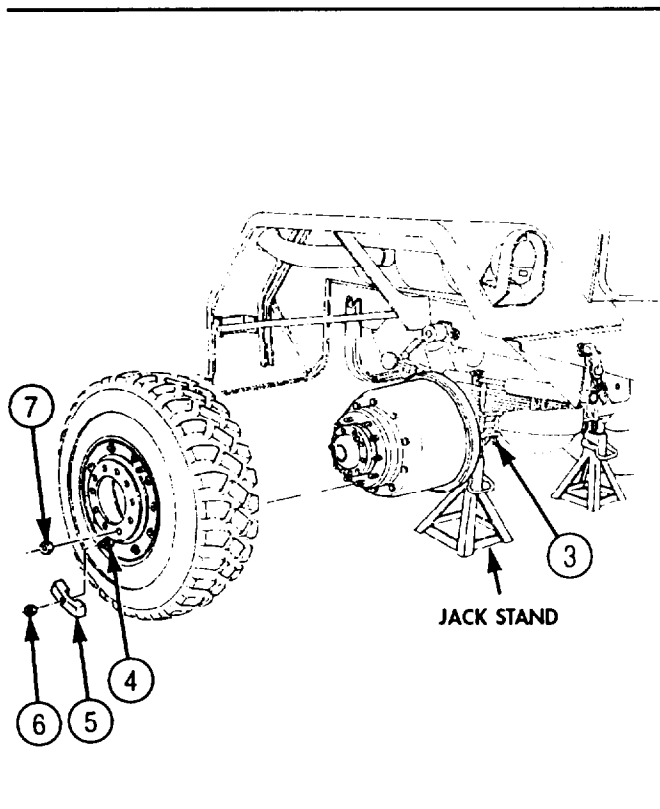
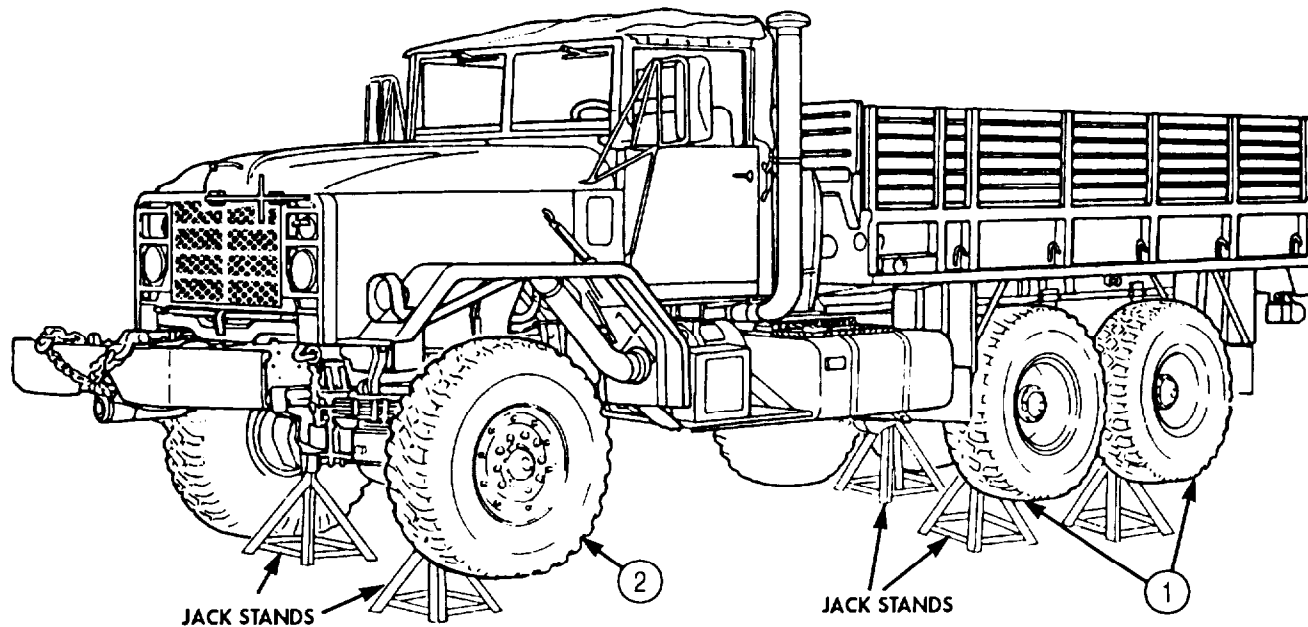

3-219. WHEEL AND TIRE (M939A1/A2) ROTATION (Contd)

c. Wheel and Tire Rotation

NOTE

- Wheels and tires are rotated the same for all M939A1/A2 series vehicles.
- To maintain tread depth, tires must be rotated to match tread wear as closely as possible (TM 9-2610-200-24).
- Tires (14:00xR20) have unidirectional tread design and can be installed in either direction.

Rotate wheels and tires as shown.

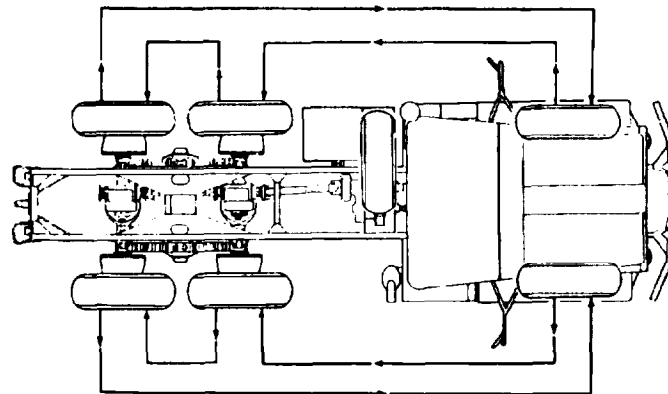

d. Rear Wheel Installation

WARNING

Apply proper torque to outer lug nuts. Failure to do so may result in injury to personnel or damage to equipment.

1. Install four rear wheels (1) on studs (3) with forty stud nuts (2). Hand-tighten stud nuts (2).
2. Raise rear of vehicle, remove jack stands, and lower vehicle.
3. Tighten forty stud nuts (2) 450-500 lb-ft (610-678 N•m) in sequence shown.

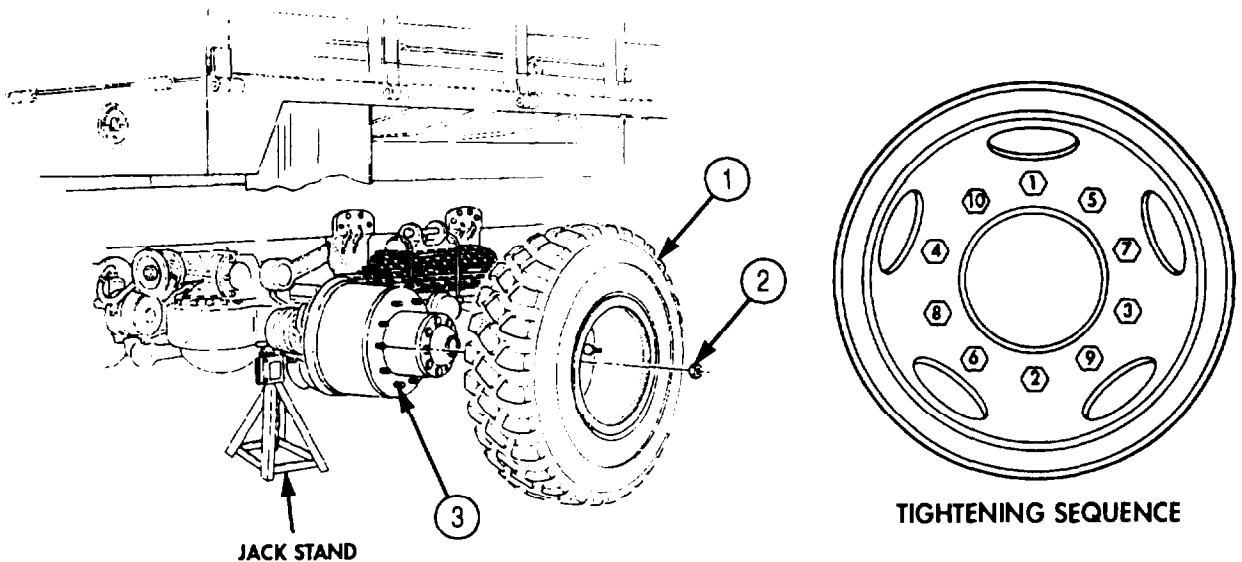

3-219. WHEEL AND TIRE (M939A1/A2) ROTATION (Contd)

e. Front Wheel Installation

WARNING

Apply proper torque to outer lug nuts. Failure to do so may result in injury to personnel or damage to equipment.

1. Install two front wheels (4) on studs (5) with twenty stud nuts (9). Hand tighten stud nuts (9).
2. Raise front of vehicle, remove jack stands, and lower vehicle.
3. Tighten twenty stud nuts (9) 450-500 lb-ft (610-678 N•m) in sequence shown.

NOTE

- Perform step 4 for M939A2 vehicles only.
 - Install wheel weight with slot flush against rim nut.
4. Install wheel weights (7) on two front wheels (4) and studs (6) with two nuts (8). Tighten nuts (8) 40 lb-ft (54 N•m).

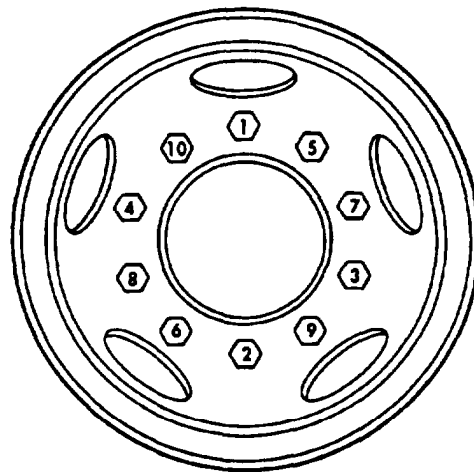
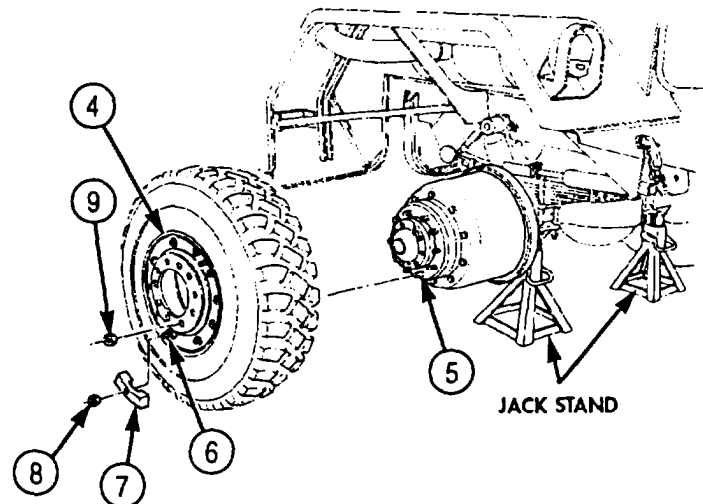

- FOLLOW-ON TASKS:
- Install front wheel valve (para. 3-456).
 - Install rear wheel valve (para. 3-457).

3-220. TIRE AND TUBE (M939) MAINTENANCE

THIS TASK COVERS:

- | | |
|--|-------------------------------|
| <p>a. Removal</p> <p>b. Inspection</p> | <p>c. Installation</p> |
|--|-------------------------------|

INITIAL SETUP:

APPLICABLE MODELS

M939

TOOLS

General mechanic's tool kit (Appendix E, Item 1)

REFERENCES (TM)

TM 9-2320-272-10
 TM 9-2320-272-24P

EQUIPMENT CONDITION

Wheel(s) removed (para. 3-218).

GENERAL SAFETY INSTRUCTIONS

- Never remove tire lockring without first deflating tire.
- Ensure lockring is properly seated around wheel before inflating tire.
- Never inflate tire with lockring facing personnel.
- Never attempt to seat lockring by striking while tire is inflating.

NOTE

Ensure tire inflation cage does not have cracked welds, cracked or bent components, or pitting from corrosion. If any of these are found, obtain new inflation cage.

a. Removal

1. Remove valve cap (11) and valve core (10) from inner tube valve stem (9).

WARNING

Never remove tire lockring without first deflating tire. Lockring may explode off, causing injury to personnel.

2. Position tire (4) on side, with lockring (1) facing upward.
3. Break tire bead (13) from lockring (1).

NOTE

Assistant will help with step 3.

4. Insert first tire iron (3) in lockring slit (2) and pry upward until slot (5) is exposed.
5. Insert second tire iron (6) into lockring slot (5) and pry upward while running first tire iron (3) completely around and remove lockring (1).
6. Break tire bead (13) on opposite side of wheel (7).
7. Remove tire (4) from wheel (7).
8. Remove tire liner (12) and inner tube (8) from tire (4).