

* This publication supersedes TM 9-2320-260-20-1, TM 9-2320-260-20-2-1, TM 9-2320-260-20-2-2, TM 9-2320-260-20-3-1, TM 9-2320-260-20-3-2, TM 9-2320-260-20-3-3, and TM 9-2320-260-20-3-4, dated 12 January 1981, for M809 Series Trucks.

TECHNICAL MANUAL UNIT MAINTENANCE

5-TON, 6X6, M809 SERIES TRUCKS (D I E S E L)

TRUCK, CARGO: 5-TON, 6X6
M813 (2320-00-050-8902) (EIC:BSB);
(2320-00-050-8890) (EIC:BSA)
M813A1 (2320-00-050-8913) (EIC:BSD);
[2320-00-050-8905) (EIC:BSC)
M814 (2320-00-050-8988) (EIC:BSK);
(2320-00-050-8987) (EIC:BSJ)

TRUCK, BOLSTER, LOGGING: 5-TON, 6X6
M815 (2320-00-050-8927) (EIC:BSE)

TRUCK, WRECKER, MEDIUM 5-TON, 6X6
M816 [2320-00-051-0489) (EIC:BSQ)

TRUCK, DUMP: 5-TON, 6X6
M817 (2320-00-050-8970) (EIC:BSF);
(2320-00-051-0589) (EIC:BSR)

TRUCK, TRACTOR 5-TON, 6X6
M818 (2320-00-050-8984) (EIC:BSH);
(2320-00-050-8978) (EIC:BSG)

TRUCK, TRACTOR, WRECKER 5-TON, 6X6
M819 (2320-00-050-9004) (EIC:BSL)

TRUCK, VAN, EXPANSIBLE: 5-TON, 6X6
M820 {2320-00-050-9006) (EIC:BSM)
M820A1 (2320-00-050-9007)
M820A2 (2320-00-050-9010) (EIC:BSN)

TRUCK, STAKE, BRIDGE TRANSPORTING: 5-TON, 6X6
M821 [2320-00-050-9015) [EIC:BSP)

DISTRIBUTION STATEMENT A. Approved for public release;
distribution is unlimited.

HOW TO USE THIS MANUAL	v
INTRODUCTION	1-1
SERVICE AND TROUBLESHOOTING INSTRUCTIONS	2-1
ENGINE SYSTEMS MAINTENANCE	3-1
ELECTRICAL SYSTEM MAINTENANCE	4-1
TRANSMISSION MAINTENANCE	5-1
TRANSFER CASE SYSTEM MAINTENANCE	6-1
PROPELLER SHAFTS, AXLES, AND SUSPENSION SYSTEM MAINTENANCE	7-1
MECHANICAL PARKING BRAKE, COMPRESSED AIR, AND SERVICE BRAKE SYSTEM MAINTENANCE	8-1
WHEELS, HUBS, DRUMS, AND STEERING SYSTEM MAINTENANCE	9-1
FRAME MAINTENANCE	10-1
BODY, CAB, AND ACCESSORIES MAINTENANCE	11-1
SPECIAL PURPOSE BODIES MAINTENANCE	12-1
HOIST, WINCH, CRANE, AND POWER TAKEOFF MAINTENANCE	13-1
SPECIAL PURPOSE KITS MAINTENANCE	14-1
SHIPMENT AND LIMITED STORAGE	15-1

WARNING

EXHAUST GASES CAN KILL

1. DO NOT operate your vehicle engine in enclosed area.
 2. DO NOT idle vehicle engine with cab windows closed.
 3. DO NOT drive vehicle with inspection plates or cover plates removed.
 4. BE ALERT at all times for exhaust odors.
 5. BE ALERT for exhaust poisoning symptoms. They are:
 - Headache
 - Dizziness
 - Sleepiness
 - Loss of muscular control
 6. If YOU SEE another person with exhaust poisoning symptoms:
 - Remove person from area
 - Expose to open air
 - Keep person warm
 - Do not permit person to move
 - Administer artificial respiration, if necessary*
- * For artificial respiration, refer to FM 21-11.

WARNING SUMMARY

- Drycleaning solvent is flammable and will not be used near open flame. Use only in well-ventilated places. Failure to do so may result in injury to personnel.
- Do not perform battery system checks or inspections near open flame. Injury to personnel may result.
- Diesel fuel is highly flammable. Do not perform troubleshooting checks near open flame. Injury to personnel may result.
- Compressed air source will not exceed 30 psi (207 kPa). When cleaning with compressed air, eyeshields must be worn. Failure to wear eyeshields may result in injury to personnel.
- Care should be taken when removing surge tank filler cap. Steam or hot coolant under pressure may cause injury to personnel.
- Do not perform this procedure while smoking or within 50 feet of sparks or open flame. Fuel is flammable and can explode easily, causing injury or death to personnel and damage to equipment.
- Do not use compressed air or dry brush for cleaning when working in areas of vehicle where asbestos brake lining dust may accumulate. Remove asbestos dust and other residue from these areas using a soft bristle brush or cloth soaked with water. Breathing asbestos dust may cause injury to personnel.
- Loosen outlet line at air compressor very slowly. Stop procedure and tighten fitting the moment air begins to escape. Injury to personnel may result if line is accidently disconnected from serviceable operating compressor.

WARNING SUMMARY (Contd)

- Do not look into service chamber vent port when performing test. Injury to personnel may result.
- Do not disconnect air lines before draining air reservoir. Small parts under pressure may shoot out with high velocity, causing injury to personnel.
- Do not look into limiting valve vent port when performing test. Injury to personnel may result.
- Wear protective mask and work in well-ventilated area when removing glaze from brakeshoes. Asbestos dust may form during glaze removal, causing harm to your health if inhaled.
- Loosen supply line at valve very slowly. Stop procedure and tighten fitting of supply line the moment air begins to escape. Injury to personnel may result if supply line is disconnected from valve.
- Loosen delivery line at valve very slowly. Stop procedure and tighten fitting of delivery line the moment air begins to escape. Injury to personnel may result if delivery line is disconnected from valve.
- Do not look into parking brake valve vent port when performing test. Injury to personnel may result.
- Battery acid (electrolyte) is extremely harmful. Always wear safety goggles and rubber gloves, and do not smoke when performing battery maintenance. Severe injury will result if acid contacts eyes or skin.
- Remove all jewelry such as rings, dog tags, bracelets, etc. If jewelry or disconnected battery ground cable contact battery terminal, a direct short can result, causing instant heating of tools, severe injury to personnel, or damage to equipment.
- When removing battery cables, disconnect ground cable first. Do not allow tools to come in contact with vehicle when disconnecting cable clamps. A direct short can result, causing instant heating of tools, injury to personnel, tool damage, battery damage, or battery explosion.
- Some vehicles have two separate wires and connectors. Mark wires for installation. Connecting wires on wrong terminals may cause fuel to ignite, resulting in injury to personnel.
- Do not perform testing near fuel tank with fill cap or sending unit removed. Fuel may ignite, causing injury to personnel.
- Do not drain oil when engine is hot. Injury to personnel may result.
- If NBC exposure is suspected, all air filter media should be handled by personnel wearing protective equipment. Consult your unit NBC officer or NBC NCO for appropriate handling or disposal instructions.
- NBC contaminated filters must be handled using adequate precautions (FM 21-40) and must be disposed of by trained personnel.
- Diesel fuel is flammable. Do not perform fuel system procedures near open flame. Injury to personnel may result.
- Do not touch hot exhaust system components with bare hands. Injury to personnel may result.
- Care must be taken while removing surge tank cap when engine temperature is above 175°F (79°C). Escaping steam or hot coolant may cause injury to personnel.
- Use caution when testing thermostat. Hot water may cause injury to personnel.
- Use care when removing fan blade. Failure to do so may cause injury to personnel.
- Eye protection must be worn when removing or installing springs under tension. Failure to do so may result in injury to personnel.
- Do not smoke, have open flame, or make sparks when performing battery maintenance. Batteries may explode, causing severe injury to personnel.
- Do not wear jewelry when repairing harnesses. Injury to personnel may result if circuit is suddenly energized.

Warning b

WARNING SUMMARY (Contd)

- Brakeshoe springs are under high tension. Use brake spring pliers to replace brakeshoe retracting springs. Other tools may fail to hold spring, causing injury to personnel.
- When removing spring hanger pins, personnel must stand clear of spring ends. Tension may cause spring to snap out of hanger, resulting in injury to personnel.
- Leaves and plates of assembled spring are under tension. Release tension slowly. Failure to do this may result in injury to personnel.
- Eye protection is required when using wire brush for cleaning. Failure to do this may result in injury to personnel.
- Use of C-clamps on spring assembly places this unit under tension. Do not complete assembly until center screw nut is tightened to specification. Failure to do this may result in injury to personnel.
- When removing spring shackle pins, personnel must stand clear of spring ends. Tension may cause spring to snap out of shackle, causing injury to personnel.
- Ensure vehicle is firmly supported while spring seat is removed. Failure to do so may result in injury to personnel.
- Incorrect brakeshoe installation will prevent automatic adjusters from working. The longer radius end of brakeshoe web must ride on the adjustable plunger. Incorrect brakeshoe installation may cause vehicle brakes to fail, resulting in serious injury or death to personnel.
- Do not remove switch before draining air reservoirs. Small parts under pressure may shoot out with high velocity, causing injury to personnel.
- Do not work under vehicle that is supported by jack only. Jack may slip, causing vehicle to fall, and result in injury or death to personnel.
- Never remove tire lockring before deflating tire. Lockring may explode off, causing injury or death to personnel.
- Lockring must be properly seated around wheel when installed. If lockring is not correctly installed, it may explode off when tire is inflated, causing injury or death to personnel.
- Never attempt to correct seating of lockring by hammering, striking, or forcing while tire is inflated. Lockring may explode off, causing injury or death to personnel.
- Never inflate a tire with tire lockring facing personnel or without a tire inflation cage. Injury or death to personnel may result from exploding wheel components.
- Always use tire inflation equipment specified in TM 9-2610-200-24 and stand 10 ft (3.05 m) away from tire inflation cage while inflating tire. Injury or death may result from exploding wheel components.
- Never rest or lean against tire inflation cage while tire is being inflated. Injury or death to personnel may result.
- Keep fingers clear of hood and cowling when replacing hinge. Failure to do so may result in injury to personnel.
- Support cab body while in raised position for insulator replacement. Failure to do so may result in injury to personnel.
- All personnel must stand clear during lifting operations. A swinging or shifting load may cause injury to personnel.
- Ensure locking handles at forward end of dropsides are engaged before removing tailgate. Failure to do so may cause injury to personnel.
- Use eyeshields and gloves when removing and installing door window glass. Glass could shatter, causing injury to personnel.

WARNING SUMMARY (Contd)

- Support hinged roof panel before removing counterbalance cable. Failure to do so may cause injury to personnel.
- Wear hand protection when handling winch cable. Broken wires may cause injury to personnel.
- Never stand between vehicles. Assistant must remain in secondary vehicle to engage service brakes if cable snaps or automatic brake fails. Failure to do this may result, in injury to personnel.
- A minimum of four turns of cable must remain on winch drum at all times. Failure to do this may result in injury to personnel or damage to equipment.
- Always use hand throttle to control engine speed when operating winch. Avoid sudden changes in speed. Rough or jerky operations may cause a shearpin to break or cable to snap. Damage to vehicle or injury to personnel may result.
- Brakeband cover and adjustment screw maybe too hot to proceed with this task. If cover and screw are too hot, allow them to cool before continuing with adjustment. Failure to do this may result in injury to personnel.
- Do not remove slave receptacle before disconnecting battery ground cables. If energized battery cables contact cab, a direct short will result and may cause injury to personnel.
- Cleaning solvents are flammable and will not be used near open flame. Use only in well-ventilated places. Failure to do so may result in injury to personnel.
- Stay clear of moving parts while engine is running. Failure to do so may result in injury or death to personnel.
- Do not operate a deadline vehicle without preliminary inspection. Failure to do so may cause further damage to a disabled component and possible injury to personnel.
- Do not use a dry brush or compressed air to clean brakeshoes. There maybe asbestos dust on brakeshoes which can be dangerous to your health if you breathe it. (Brakeshoes must be wet; use a soft bristle brush.)

TECHNICAL MANUAL
NO. 9-2320-260-20

DEPARTMENTS OF THE ARMY
AND THE AIR FORCE

TECHNICAL ORDER
No. 36A12-IC-491

WASHINGTON, D.C. 28 April 1995

TECHNICAL MANUAL
UNIT MAINTENANCE
FOR
5-TON, 6X6, M809 SERIES TRUCKS
(DIESEL)

Model		NSN Without Winch (EIC)	NSN With Winch (EIC)
Truck, Cargo	M813	2320-00-050-8902 (BSB)	2320-00-050-8890 (BSA)
	M813A1	2320-00-050-8913 (BSD)	2320-00-050-8905 (BSC)
	M814	2320-00-050-8988 (BSK)	2320-00-050-8987 (BSJ)
Truck, Bolster, Logging	M815		2320-00-050-8927 (BSE)
Truck, Wrecker, Medium	M816		2320-00-051-0489 (BSQ)
Truck, Dump	M817	2320-00-050-8970 (BSF)	2320-00-051-0589 (BSR)
Truck, Tractor	M818	2320-00-050-8984 (BSH)	2320-00-050-8978 (BSG)
Truck, Tractor, Wrecker	M819		2320-00-050-9004 (BSL)
Truck, Van, Expansible	M820	2320-00-050-9006 (BSM)	
	M820A1	2320-00-050-9007	
	M820A2	2320-00-050-9010 (BSN)	
Truck, Stake, Bridge Transporting	M821		2320-00-050-9015 (BSP)

* This publication supersedes TM 9-2320-260-20-1, TM 9-2320-260-20-2-1, TM 9-2320-260-20-2-2, TM 9-2320-260-20-3-1, TM 9-2320-260-20-3-2, TM 9-2320-260-20-3-3, and TM 9-2320-260-20-3-4, dated 12 January 1981, for M809 Series Trucks.

DISTRIBUTION STATEMENT A. Approved for public release;
distribution is unlimited.

REPORTING OF ERRORS

You can help improve this manual. If you find any mistakes or if you know of a way to improve the procedures, please let us know. Mail your letter, DA Form 2028 (Recommended Changes to Publications and Blank Forms), or DA Form 2028-2 located in back of this manual direct to: Commander, U.S. Army Tank-Automotive Command, ATTN: AMSTA-MB, Warren, Michigan 48397-5000. A reply will be furnished to you.

	Page
HOW TO USE THIS MANUAL	v
CHAPTER 1 INTRODUCTION	1-1
Section I. General Information	1-1
II. Equipment Description and Data	1-3
III. Principles of Operation	1-36
CHAPTER 2 SERVICE AND TROUBLESHOOTING INSTRUCTIONS	2-1
Section I. Repair Parts, Special Tools, TMDE, and Support Equipment	2-1
II. Service Upon Receipt	2-1
III. Preventive Maintenance Checks and Services (PMCS)	2-2
IV. Mechanical Systems Troubleshooting	2-66
V. Compressed Air and Air-Hydraulic Brake System Troubleshooting	2-88
VI. Electrical Systems Troubleshooting	2-96
VII. STE/ICE Troubleshooting (Simplified Test Equipment for Internal Combustion Engines)	2-186
CHAPTER 3 ENGINE SYSTEMS MAINTENANCE	3-1
Section I. Engine Lubrication System Maintenance	3-1
II. Clutch System Maintenance	3-16
III. Air Intake System Maintenance	3-23
IV. Fuel System Maintenance	3-32
V. Accelerator System Maintenance	3-68
VI. Exhaust System Maintenance	3-74
VII. Cooling System Maintenance	3-84
CHAPTER 4 ELECTRICAL SYSTEM MAINTENANCE	4-1
Section I. Charging System Maintenance	4-1
II. Starting System Maintenance	4-10
III. Instruments, Sending Units, Switches, and Horn Maintenance	4-13
IV. Lighting System Maintenance	4-66
V. Battery System Maintenance	4-90
VI. Wiring Circuits and Harness Maintenance	4-106

CHAPTER 5	TRANSMISSION MAINTENANCE	5-1
CHAPTER 6	TRANSFER CARE SYSTEM MAINTENANCE	6-1
CHAPTER 7	PROPELLER SHAFTS, AXLES, AND SUSPENSION SYSTEM MAINTENANCE	7-1
Section I.	Propeller Shafts Maintenance	7-1
II.	Front and Rear Axle Maintenance	7-13
III.	Front and Rear Suspension Maintenance	7-27
CHAPTER 8	MECHANICAL PARKING BRAKE, COMPRESSED AIR, AND SERVICE BRAKE SYSTEM MAINTENANCE	8-1
Section I.	Mechanical Parking Brake Maintenance	8-1
II.	Service Brakes and Hydraulic System Maintenance	8-13
III.	Compressed Air and Brake System Maintenance	8-38
CHAPTER 9	WHEELS, HUBS, DRUMS, AND STEERING SYSTEM MAINTENANCE	9-1
Section I.	Wheels, Hubs, and Drums Maintenance	9-1
II.	Steering System Maintenance	9-21
CHAPTER 10	FRAME MAINTENANCE	10-1
CHAPTER 11	BODY, CAB, AND ACCESSORIES MAINTENANCE	11-1
Section I.	Body and Cab Maintenance	11-1
II.	Accessory Items Maintenance	11-67
CHAPTER 12	SPECIAL PURPOSE BODIES MAINTENANCE	12-1
Section I.	Cargo Body Maintenance	12-1
II.	Dump Body Maintenance	12-21
III.	Van Body Maintenance	12-34
IV.	Wrecker Body Maintenance	12-101
V.	Tractor Wrecker Body Maintenance	12-116
VI.	Bolster Body Maintenance	12-122
VII.	Tractor Body Maintenance	12-130
CHAPTER 13	HOIST, WINCH, CRANE, AND POWER TAKEOFF MAINTENANCE	13-1
Section I.	Hoist and Winch Maintenance	13-1
II.	Power Divider Maintenance	13-123
III.	Power Takeoff Maintenance	13-134

CHAPTER 14	SPECIAL PURPOSE KITS MAINTENANCE	14-1
Section I.	Winterization Kits Maintenance	14-1
II.	Deepwater Forging Kit Maintenance	14-52
III.	A-Frame Kit Maintenance	14-58
IV.	Mounting Kit Maintenance	14-62
V.	Mini Lighting Kit Maintenance	14-72
VI.	100-Amp Alternator Kit Maintenance	14-78
VII.	Troop Seat and Seatbelt Kits Maintenance	14-84
VIII.	Hand Airbrake Kit Maintenance	14-90
IX.	Tachograph Kit Maintenance	14-92
X.	Convoy Warning Light Kit Maintenance	14-96
XI.	Van Cable Reel Kit Maintenance	14-116
CHAPTER 15	SHIPMENT AND LIMITED STORAGE	15-1
Section I.	General Preparation of Truck for Shipment	15-1
II.	Loading and Movement	15-2
III.	Limited Storage	15-2
APPENDIX A	REFERENCES	A-1
APPENDIX B	MAINTENANCE ALLOCATION CHART	B-1
APPENDIX C	EXPENDABLE/DURABLE SUPPLIES AND MATERIALS LIST	C-1
APPENDIX D	TORQUE LIMITS	D-1
APPENDIX E	SCHEMATIC AND WIRING DIAGRAMS	E-1
INDEX	Index 1

HOW TO USE THIS MANUAL

ABOUT YOUR MANUAL

Spend some time looking through this manual. You'll find that it has a new look, different than most of the TM's you've been using.

New features added to improve the convenience of this manual and increase your efficiency are:

- a. Accessing Information** - These include features such as the bleed-to-edge locators on the cover and edge of the manual. Extensive troubleshooting guides for specific systems lead directly to step-by-step directions for problem solving and maintenance tasks.
- b. Illustrations** - A variety of methods are used to make locating and fixing components much easier. Locator illustrations with keyed text, exploded views, and cut-away diagrams make the information in this manual easier to understand and follow.
- c. Modification or Special Purpose Kits** - M809 series vehicles can be updated with modification kits or equipped with special purpose kits. They allow the vehicle to operate more efficiently or perform a special function. Sometimes the vehicle being worked on doesn't exactly match the maintenance procedure in this manual because the proper kit has not been installed. Refer to troubleshooting sections in chapter 2 to find troubleshooting instructions or a reference to kit installation instructions.
- d. Keying Text With Illustrations** - Illustration and text are located on facing pages that show the specific task you are working on. In some cases, the task steps and illustrations are located side by side. Continue reading for an example of modular text and illustrations.
- e. General Features** - Your TM is the best source available for providing information and data critical to vehicle operation and maintenance:
 - Safety summary (warning pages a, b, c, and d)
 - General information, equipment description, and data (chapter 1, sections I and II)
 - Principles of operation (chapter 1, section III)
 - Preventive Maintenance Checks and Services - PMCS (chapter 2, section III)
 - Systems Troubleshooting (chapter 2, sections IV, V, VI, and VII)
 - Detailed maintenance procedures (chapters 3 through 14)
 - Shipment and limited storage (chapter 15, sections I, II, and III)
 - References (appendix A)
 - Maintenance Allocation Chart - MAC (appendix B)
 - Expendable/durable supplies and materials list (appendix C)
 - Torque limits (appendix D)
 - Schematic and Wiring Diagrams (appendix E)

Atypical example of how to use this manual is provided on the following pages.

USING YOUR MANUAL: AN EXAMPLE

TASK: The operator of a M809 series vehicle, model number M813A1, has complained of excessive exhaust noise and exhaust fumes entering the cab of his vehicle. The vehicle has been assigned to you for repair.

TROUBLESHOOTING STEPS:

1. Look at the cover of this manual. You'll see chapter/section titles listed from top to bottom on the right-hand side.
2. Look at the right-edge of the manual. On some of the pages you'll see edge indicators (black bars) that are aligned with the chapter/section bars on the cover. These are the locations of the chapters/sections in the text.
3. Look for "SERVICE AND TROUBLESHOOTING INSTRUCTIONS" in the chapter list on the cover. This is where the troubleshooting information is located.
4. Turn to those pages with the edge indicator matching the black bar for service and troubleshooting instructions. Page numbers are also listed next to chapter/section titles.
5. Chapter 2 is divided into seven sections:
 - Section I - Repair Parts, Special Tools, TMDE, and Support Equipment
 - Section II - Service Upon Receipt
 - Section III - Preventive Maintenance Checks and Services (PMCS)
 - Section IV - Mechanical Systems Troubleshooting
 - Section V - Compressed Air and Air-Hydraulic Brake System Troubleshooting
 - Section VI - Electrical Systems Troubleshooting
 - Section VII - STE/ICE Troubleshooting
6. Turn to section IV, "MECHANICAL SYSTEMS TROUBLESHOOTING" (page 2-22). This troubleshooting section is system-oriented and is broken down into 23 major vehicle systems.
7. One of the first pages of this section is the "MECHANICAL TROUBLESHOOTING SYMPTOM INDEX" (turn to page 2-23).
8. Look down the list until you find "EXHAUST SYSTEM." Beneath that heading you will find the symptoms noted by the vehicle operator: "Excessive exhaust noise" and "Exhaust fumes in cab."
9. Turn to the page indicated: 2-30.

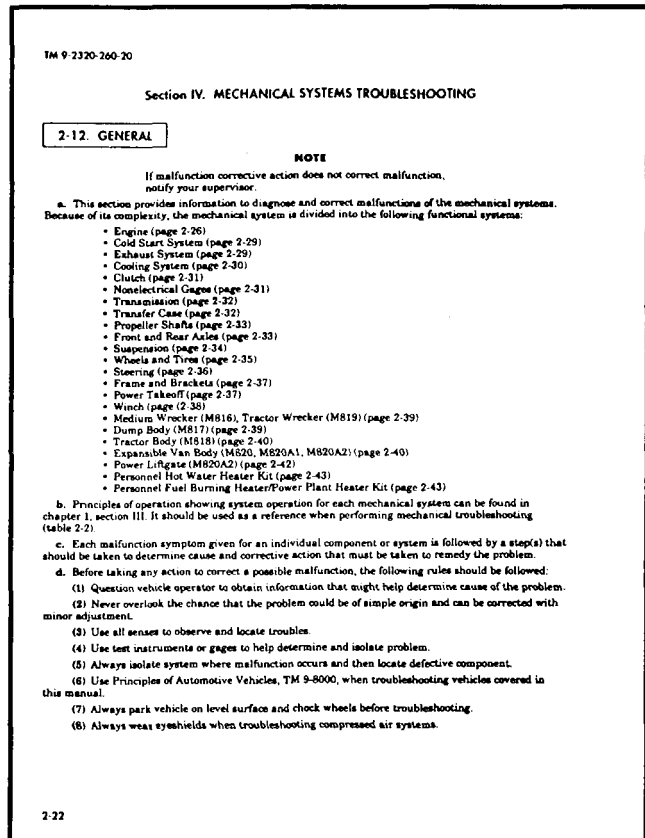
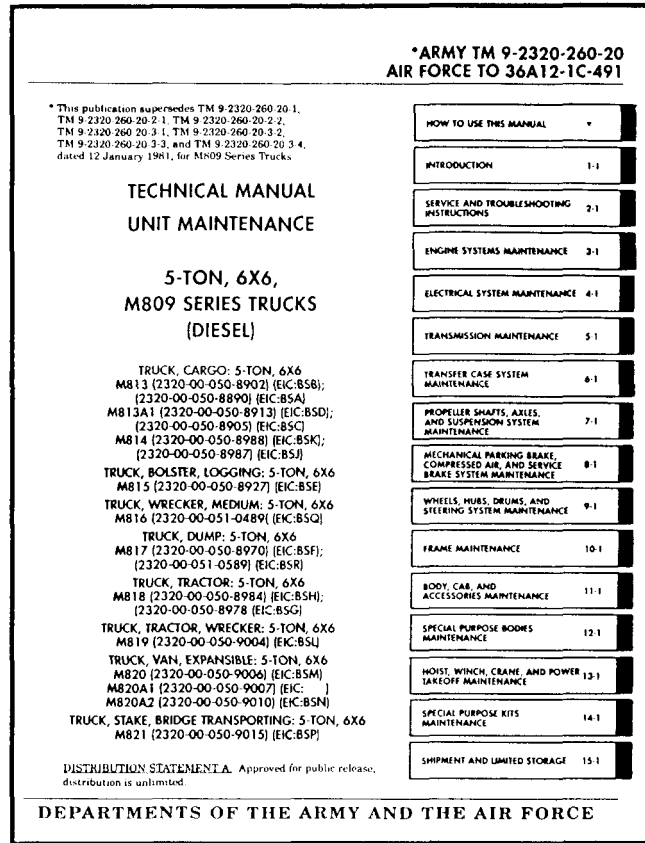

- On page 2-30, step/test relating to resolving the problem of "Excessive exhaust noise" is listed:

step 1. During your inspection, you discover that an exhaust pipe is cracked and rusted. The part must be replaced. Chapter 3, section VI is referenced.

- Turn to the "TABLE OF CONTENTS" and find the chapter dealing with the engine. You find it as "CHAPTER 3, ENGINE SYSTEMS MAINTENANCE." Furthermore, you note that the chapter is divided into seven sections. You are interested in "Section VI. Exhaust System Maintenance."

NOTE: Before attempting to repair or replace the exhaust system, as a Unit mechanic, you must:

- Determine the maintenance responsibility of repair or replacement of the component.
- If the task is at your echelon of maintenance responsibility, you must identify the tools needed and the replacement parts required.

Refer to the Maintenance Allocation Chart - MAC (appendix B) to determine not only the maintenance responsibility of the item, but also to obtain an estimate of the time required to perform the task, tools needed, and any special notes/requirements necessary.

Refer to TM 9-2320-260-20P, Unit Maintenance Repair Parts and Special Tools List for M809 Series Vehicles, for requisition data concerning replacement parts for this task.

- Turn to chapter 3, section VI, which covers "EXHAUST SYSTEM MAINTENANCE." In the maintenance index we find that there are four paragraphs listed.
- Paragraph 3-41 is a task for replacing the exhaust system used only on model M821 vehicles. All other M809 series vehicles will follow para. 3-40 for replacement of the exhaust system. Notice that, in this case, it starts on page 3-76.
- The first two pages shown have procedures and illustrations for performing the removal steps for components of the exhaust system.

TM 9-2320-260-20

Table 3-2. Mechanical Troubleshooting (Contd.)

MALFUNCTION TEST OR INSPECTION	CORRECTIVE ACTION
Step 2. If problem persists, notify your supervisor. END OF TESTING!	
16. EXCESSIVE EXHAUST NOISE	Inspect exhaust pipes for secure connections, cracks, breaks, and excessive rust. Replace damaged parts (chapt. 3, section VI). END OF TESTING!
17. EXHAUST FUMES IN CAB	Inspect exhaust manifold, exhaust pipes, muffler, and connections for leaks. a. Replace damaged parts (chapter 3, section VI). b. If exhaust manifold is leaking or damaged, notify your supervisor. END OF TESTING!
COOLING SYSTEM	
18. ENGINE COOLANT TEMPERATURE GAGE ABOVE 230°F (110°C).	WARNING Care should be taken when removing surge tank filler cap. Steam or hot coolant under pressure may cause injury to personnel. Step 1. Check coolant protection level with antifreeze tester. CAUTION Do not add coolant when engine is hot. Internal engine damage could result. If coolant is not within safe range, service cooling system (para. 3-45). Step 2. Inspect drivebelts and drive pulleys of accessories for damage and check belt tension. a. Replace or adjust drivebelts (para. 3-52, 3-54, 4-4, or 9-16). b. Replace accessory if drive pulley will not turn (para. 3-49, 3-55, 4-2, or 9-17). Step 3. Inspect radiator, hoses and hose connections, drain valves, and surge tank for leaks. a. Tighten hose clamps and fittings. b. Replace defective cooling system components (chapter 3, section VII). c. Tighten or close drain valves. d. Replace leaking radiator (para. 3-50). e. Replace leaking surge tank (para. 3-48). Step 4. Inspect fan blade for broken or missing blades. Replace fan blade (para. 3-63). Step 5. Inspect radiator for bent fins and airflow obstructions. Straighten bent fins, clear obstructions, or replace radiator (para. 3-50). Step 6. Check cooling system for restriction. Clean and flush system (para. 3-45). Step 7. Check operation of temperature gage (table 2-4, electrical troubleshooting, malfunction 30). Replace thermostat if condition continues (para. 3-47). END OF TESTING!

2-30

TM 9-2320-260-20

Section VI. EXHAUST SYSTEM MAINTENANCE

3-39. EXHAUST SYSTEM MAINTENANCE INDEX

PARA. NO.	TITLE	PAGE NO.
3-40	Vertical Exhaust Pipe Replacement	3-74
3-41	Horizontal Exhaust Pipe Maintenance (M821)	3-76
3-42	Exhaust Muffler Replacement	3-80
3-43	Exhaust Muffler Bracket Maintenance	3-82

3-40. VERTICAL EXHAUST PIPE REPLACEMENT

THIS TASK COVERS:

a. Removal	b. Installation
------------	-----------------

INITIAL SETUP

APPLICABLE MODELS All	REFERENCES (TM) TM 9-2320-260-10 TM 9-2320-260-20P
MATERIALS/PARTS Two locking plates Clasket Ten locknuts Antiseize compound (Appendix C, Item 5)	EQUIPMENT CONDITION Parking brake set (TM 9-2320-260-10). GENERAL SAFETY INSTRUCTIONS Do not perform this task when exhaust system is hot.

WARNING

Do not touch hot exhaust system components with bare hands. Injury to personnel may result.

a. Removal

- Remove two clamps (13) from exhaust pipe (22).
- Remove four locknuts (26), screws (24), washers (23), two brackets (12), and exhaust shield (25) from exhaust pipe (22). Discard locknuts (26).
- Remove two locknuts (4), washers (3), U-clamp (27), and exhaust stack (1) from bracket (2) and exhaust pipe (22). Discard locknuts (4).
- Bend tabs of two locking plates (31) away from screws (20).
- Remove four screws (20), two locking plates (31), exhaust pipe (22), and gasket (19) from right front fender (17) and muffler (18). Discard locking plates (31) and gasket (19).
- Remove locknut (11), screw (6), two washers (7), springs (8), and bracket (2) from bracket (3). Discard locknut (11).
- Remove locknut (15), screw (9), two locknuts (16), screws (10), and bracket (8) from gun mount bracket (14). Discard locknuts (15) and (16).

3-74

DETAILED MAINTENANCE PROCEDURES:

15. Detailed procedures: Include everything you must do to accomplish a basic maintenance task.
- a. Before beginning the maintenance task, look through the procedure. You must familiarize yourself with the entire maintenance procedure before beginning the maintenance task. The entire procedure of paragraph 3-40: "VERTICAL EXHAUST PIPE MAINTENANCE" includes: a. Removal and b. Installation.
 - b. The eight basic headings listed under "INITIAL SETUP" outline special tools, materials, personnel requirements, and special conditions. Headings will not be listed if there are no entries. The headings are:
 - APPLICABLE MODELS Any models that require that particular maintenance task.
 - TEST EQUIPMENT Test equipment needed to complete a task.
 - SPECIAL TOOLS Those special tools needed to complete a task. Common tools are not listed.
 - MATERIALS/PARTS All parts or materials needed to complete a task.
 - PERSONNEL REQUIRED The number of personnel needed to perform a task. If only one mechanic is needed, this heading will not be used. If you think that you need more help to correctly or safely complete a task (perhaps as the result of unusual conditions, etc.), alert your supervisor and ask for help.
 - REFERENCES (TM) Those additional manuals needed to complete a task.
 - EQUIPMENT CONDITION Notes the conditions that must exist before starting the task. For exhaust system replacement, the vehicle must have the parking brake set and the air cleaner element removed.
 - GENERAL SAFETY INSTRUCTIONS Summarizes all safety warnings for the maintenance task.
 - c. A step-by-step maintenance procedure follows the "INITIAL SETUP" and gives detailed instructions for the procedure. These instructions give part name and action performed. The numbers in parentheses correspond to the part's callout number in the accompanying illustration. Warnings, cautions, and notes give additional information.
 - WARNINGS – Indicate conditions, practices, or procedures which must be observed to avoid personnel injury, loss of life, or long-term health hazard.
 - CAUTIONS – Indicate conditions, practices, or procedures which must be observed to avoid damage to equipment or destruction of equipment.
 - NOTES – Include essential information of special importance, interest, or aid in job performance.
 - d. At the end of a procedure, "FOLLOW-ON TASKS" will list those additional tasks that must be performed to complete the procedure.
16. You can also use the Table of Contents (page ii) to find more information about the vehicle. For example: Principles of Operation in chapter 1.
17. Unit PMCS are presented in table 2-1 starting on page 2-4.
18. Chapter 2, section VII, STE/ICE Troubleshooting, can be used if STE/ICE is available for troubleshooting or PMCS.
19. Refer to TM 9-2320-260-20P, Unit Maintenance Repair Parts and Special Tools List for Truck, 5-Ton, 6x6, M809 Series, when requisitioning parts, special tools, and equipment for unit maintenance.
20. Your manual is easier to use once you understand its design. We hope it will encourage you to use it more often as an aid to maintenance support for M809 series vehicles.

CHAPTER 1

INTRODUCTION

- Section I. General Information (page 1-1)
 Section II. Equipment Description and Data (page 1-3)
 Section III. Principles of Operation (page 1-36)

Section I. GENERAL INFORMATION

1-1. SCOPE

- a. This technical manual contains information for unit maintenance of 5-ton, 6x6, M809 series vehicles.
- b. Vehicle model numbers and equipment names covered are:
- M813 Cargo Truck, W/W and WO/W
 - M813A1 Cargo Truck, W/W and WO/W (Dropside)
 - M814 Cargo Truck, W/W and WO/W (XLWB)
 - M815 Bolster Logging Truck, W/W
 - M816 Medium Wrecker Truck, W/W
 - M817 Dump Truck, W/W and WO/W
 - M818 Tractor Truck, W/W and WO/W
 - M819 Wrecker Tractor Truck, W/W
 - M820 and M820A1 Expansible Van Truck, WO/W
 - M820A2 Expansible Van Truck, WO/W (W/HLG)
 - M821 Bridge Transporting Stake Truck, WO/W
- c. The 5-ton, 6x6, M809 series trucks are designed for transporting and retrieving materials and personnel.

1-2. MAINTENANCE FORMS, RECORDS, AND REPORTS

Department of the Army forms and procedures used for equipment maintenance will be those prescribed by DA Pam 738-750, The Army Maintenance Management System (TAMMS).

1-3. DESTRUCTION OF ARMY MATERIEL TO PREVENT ENEMY USE

Procedures for destruction of Army equipment to prevent enemy use can be found in TM 750-244-6.

1-4. PREPARATION FOR STORAGE OR SHIPMENT

Storage and limited storage instructions are in chapter 15 of this manual. Additional information can be found in TM 746-10, Marking, Packing and Shipment of Supplies and Equipment General Packaging Instructions for Field Use.

1-5. REPORTING EQUIPMENT IMPROVEMENT RECOMMENDATIONS (EIR's)

If the design of your vehicle needs improvement, let us know. If your vehicle is in proper operating condition and there are problems with vehicle or equipment performance, send us an EIR. You, the user, are the only one who can tell us what you don't like about your equipment. It is not necessary to show a new design or a better way to perform a procedure. Just let us know why you don't like the design or performance. Put it on an SF 368 (Quality Deficiency Report). Mail it to us at Commander, U.S. Army Tank-Automotive and Armaments Command, ATTN: AMSTA-IM-MMAA Warren, Michigan 48397-5000. We'll send you a reply.

1-6. EQUIPMENT IMPROVEMENT REPORT AND MAINTENANCE DIGEST (EIR MD)

The quarterly Equipment Improvement Report and Maintenance Digest, TB 43-0001-39 series, contains valuable field information on the equipment covered in this manual. The information in the TB 43-0001-39 series is compiled from some of the Equipment Improvement Reports that you prepared on the vehicles covered in this manual. Many of these articles resulted from comments, minor alterations, proposed Modification Work Orders (MWO's), actions taken on some of your DA form 2028's (Recommended Changes to Publications), and advance information on proposed changes that may affect this manual. The information will help you in doing your job better and will help in keeping you advised of the latest changes to this manual.

1-7. WARRANTY INFORMATION

The 5-ton, 6x6, M809 series Cummins diesel engine (model NHC-250), and Dana transmission (model 6453) are warranted in accordance with TB 9-2320-295-15/21. The warranty starts on the date, found in block 23, DA Form 2408-9, in the logbook. Report all defects in material or workmanship to your supervisor, who will take appropriate action.

Section II. EQUIPMENT DESCRIPTION AND DATA

1-8. GENERAL

The 5-ton, 6x6, M809 series trucks are tactical vehicles designed for use over all types of roads and cross-country terrain, in extreme high or low temperatures and humidity. All vehicles in this series are powered by a 240 horsepower Cummins, NHC-250 series diesel engine. A five-speed manual transmission and two-speed transfer case provide ten overall speed ranges. The trucks are capable of fording hard-bottom water crossings up to 30 inches (76.2 centimeters) without a deepwater fording kit, and 78 inches (198.1 centimeters) with the kit. All trucks are also equipped with a rear pintle hook for towing operations. Two front shackles and a pin on top of the rear springs provide a ready means of lifting the truck for transportation.

1-9. EQUIPMENT DESCRIPTION AND DATA INDEX

PARA. NO.	TITLE	PAGE NO.
1-10.	Equipment Characteristics, Capabilities, and Features	1-4
1-11.	Location and Description of Major External Components	1-10
1-12.	Location and Description of Major Internal Components	1-12
1-13.	Location and Contents of Warning, Caution, and Data Plates	1-14
1-14.	Differences Between Models	1-32
1-15.	Vehicle Performance Data	1-33

1-10. EQUIPMENT CHARACTERISTICS, CAPABILITIES, AND FEATURES

a. M813 Cargo Truck, W/W and WO/W.

PURPOSE: This model is used to transport cargo and troops. The M813 has permanent steel-welded sides, making it a preferred vehicle when transporting bulky or shifting loads. Side racks have built-in troop seats which may be positioned for troop transport operations. A bow and tarpaulin kit is available.

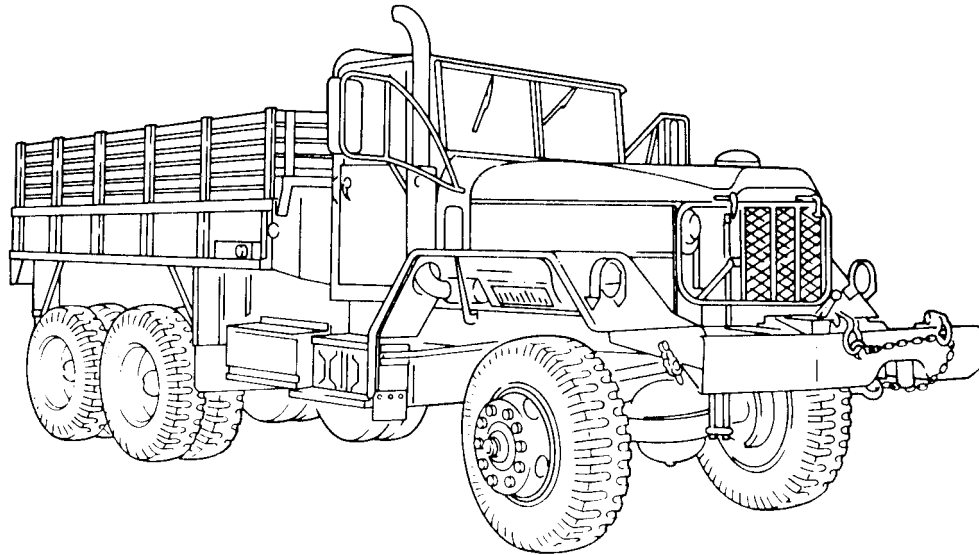

CARGO TRUCK (M813)

b. M813A1 Cargo Truck With Dropsides, W/W and WO/W.

PURPOSE: This model is used to transport cargo and troops. The hinged steel sides can be folded down or removed for easy loading and unloading operations. Side racks have built-in troop seats which may be positioned for troop transport operations. A bow and tarpaulin kit is available.

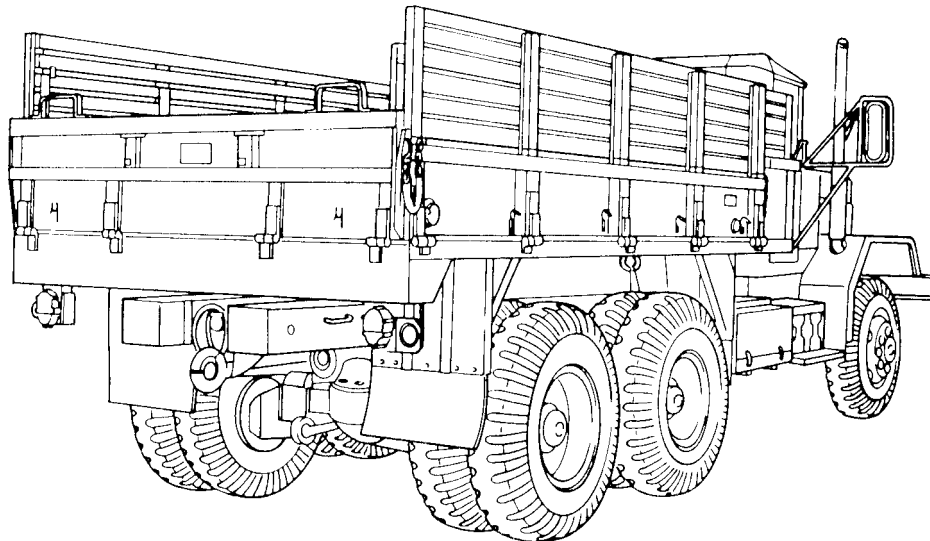

CARGO TRUCK, DROPSIDE (M813A1)

1-10. EQUIPMENT CHARACTERISTICS, CAPABILITIES, AND FEATURES (Contd)**c. M814 Cargo Truck With Extra Long Wheelbase (XLWB), W/W and WO/W.**

PURPOSE: This model has the same load capacities as the M813 and M813A1. However, the M814 truck bed is 72 in. (183 cm) longer. This provides each vehicle with an additional 744 cu ft (20.8 cu m) of cargo space. 'hop seats may be positioned for troop transport operations.

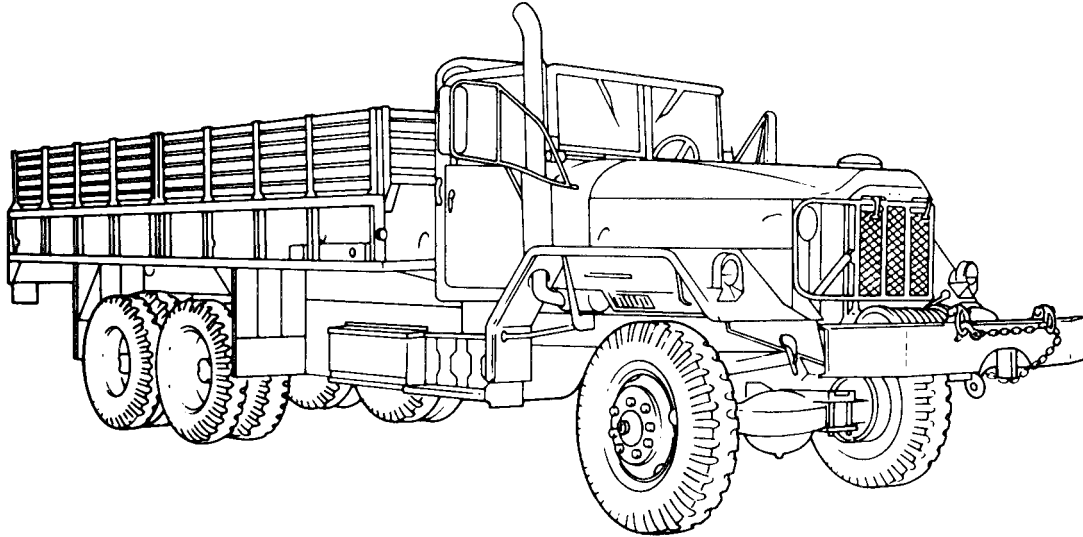
**CARGO TRUCK (M814)****d. M815 Bolster Logging Truck, W/W.**

PURPOSE: This model is used for transporting utility poles, bridge sections, and logs. It is equipped with a cab protector, front and midship winches, bolster assembly, and an adjustable M796 bolster trailer.

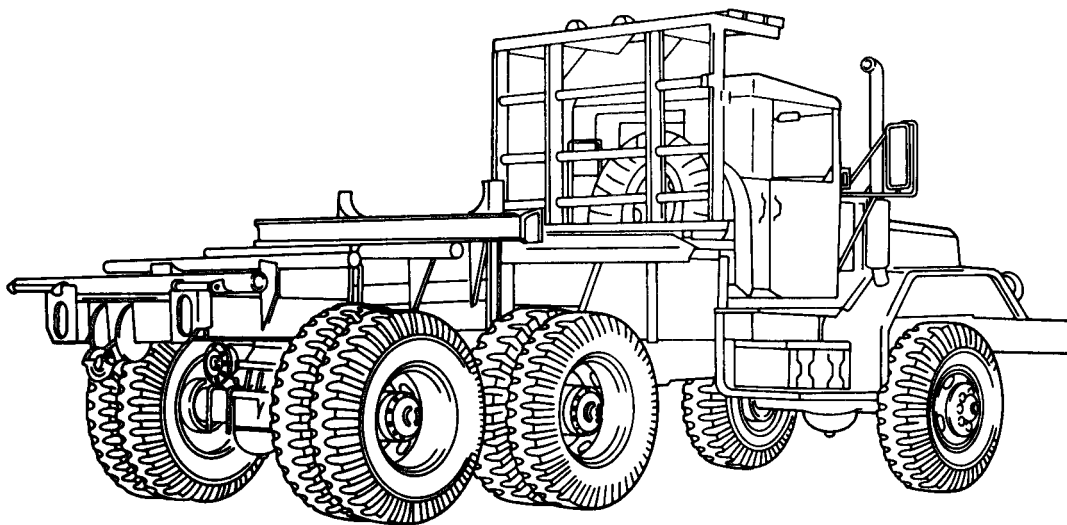
**BOLSTER LOGGING TRUCK (M815)**

1-10. EQUIPMENT CHARACTERISTICS, CAPABILITIES, AND FEATURES (Contd)

e. M816 Medium Wrecker Truck, W/W.

PURPOSE: This model is used for wrecker and salvage operations and has a revolving hydraulic crane with a self-supporting boom that can extend from 10-18 ft (3.05-5.49 m). Boom-to-ground supports are provided. Crane lifting capacity is 20,000 lb (9,080 kg). The vehicle is also equipped with a front winch [20,000 lb (9,080 kg) capacity] and rear winch [45,000 lb (20,430 kg) capacity] for freeing the vehicle when it becomes mired.

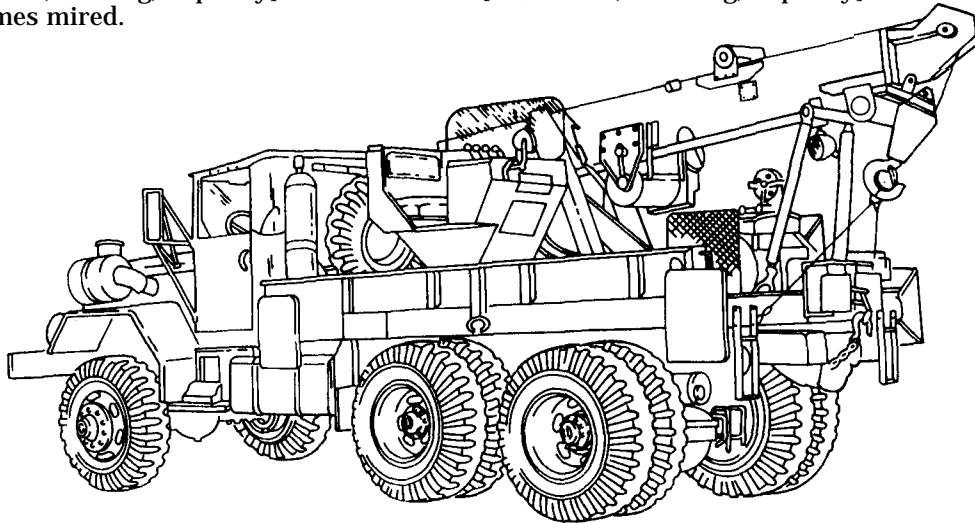

MEDIUM WRECKER TRUCK (M816)

f. M817 Dump Truck, W/W and WO/W.

PURPOSE: This model is used for hauling and dumping cargo. The body has provisions for installing side rack, troop seat, bow, and canvas kits for troop transport. It can haul up to 10,000 lb (4,540 kg) and tow up to 15,000 lb (6,810 kg) when fully loaded. The front end of the welded steel body extends up and over the vehicle cab to protect it from damage during loading operations.

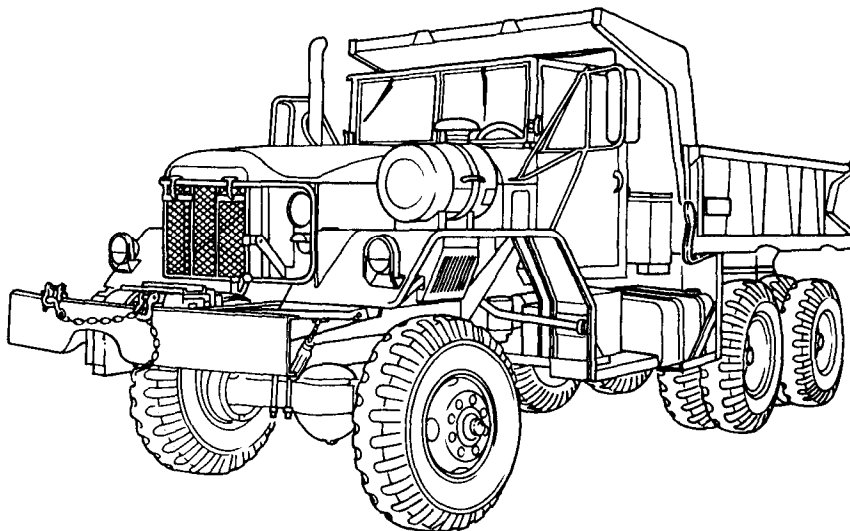

DUMP TRUCK (M817)

1-10. EQUIPMENT CHARACTERISTICS, CAPABILITIES, AND FEATURES (Contd)**g. M818 Tractor Truck, W/W and WO/W.**

PURPOSE: This model is equipped with a fifth wheel and is used to transport semitrailers. The fifth wheel is capable of pivoting up to 21 degrees up, 15 degrees down, or 7 degrees sideways. This enables the M818 to be more versatile in tactical operations under difficult conditions. Those equipped with a winch can be used for recovery operations.

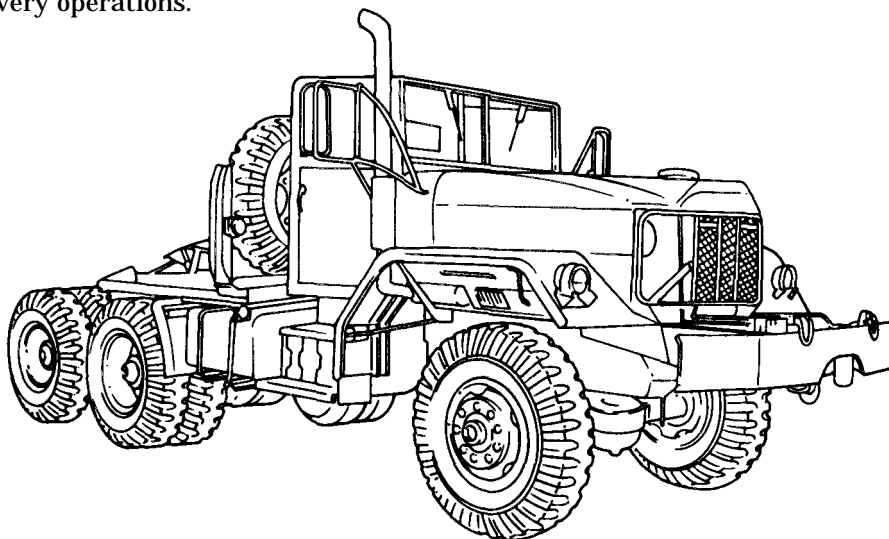

TRACTOR TRUCK (M818)

h. M819 Wrecker Tractor Truck, W/W.

PURPOSE: This model is used for wrecker, hauling, and salvage operations. It has a hydraulically-powered, engine-driven crane that is capable of extending 11.5-26 ft (3.5-7.93 m), rotating 270 degrees, and elevating 45 degrees. The M819 is also equipped with a fifth wheel for hauling semitrailers and a front winch to free the vehicle when it becomes mired.

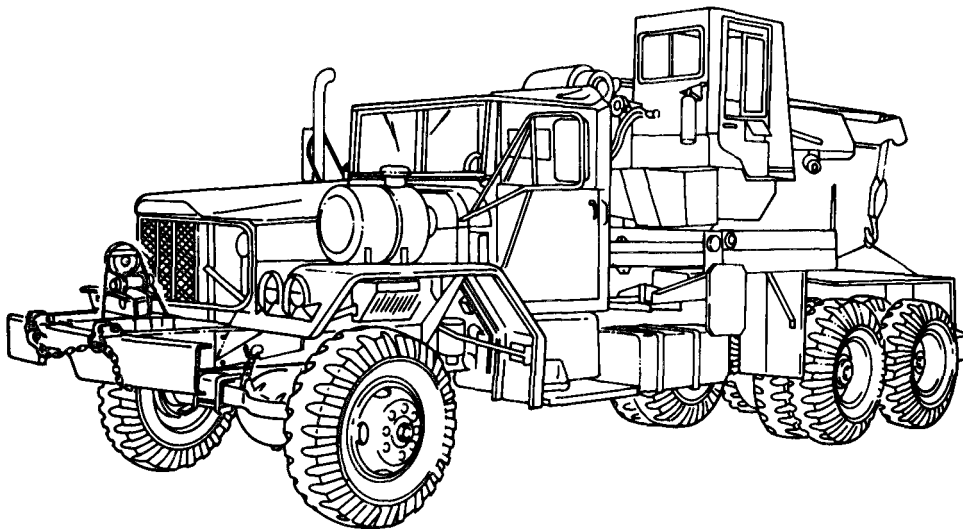

WRECKER TRACTOR TRUCK (M819)

1-10. EQUIPMENT CHARACTERISTICS, CAPABILITIES, AND FEATURES (Contd)

i. M820, M820A1, and M820A2 Expansible Van Truck, WO/W.

PURPOSE: These models are used for electrical, maintenance, supply, power, and base station operations. The M820A2 has a hydraulic liftgate [3,000 lb (1,362 kg) capacity], which makes it the preferred vehicle to use when heavy, delicate electronic equipment has to be moved in or out of the van.

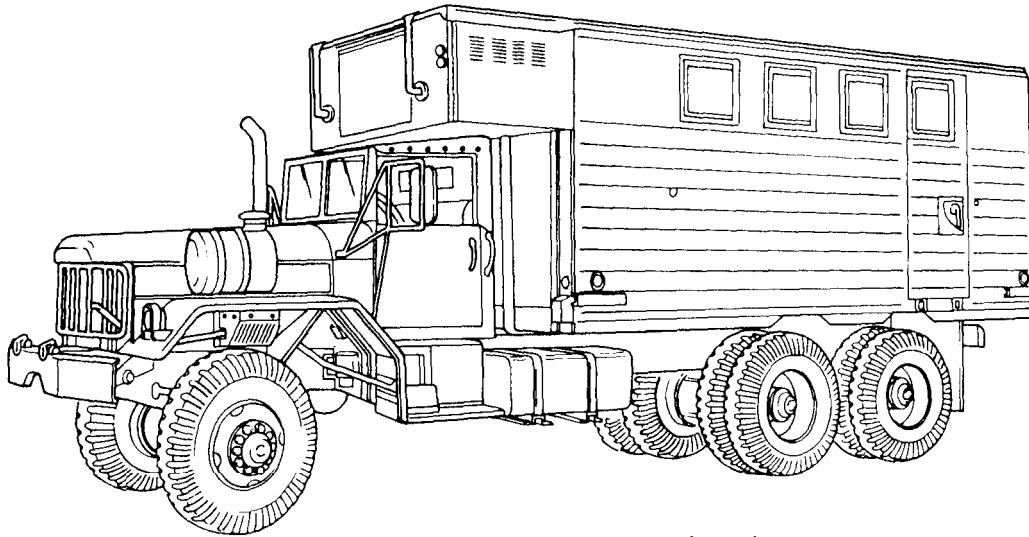

EXPANSIBLE VAN TRUCK (M820)

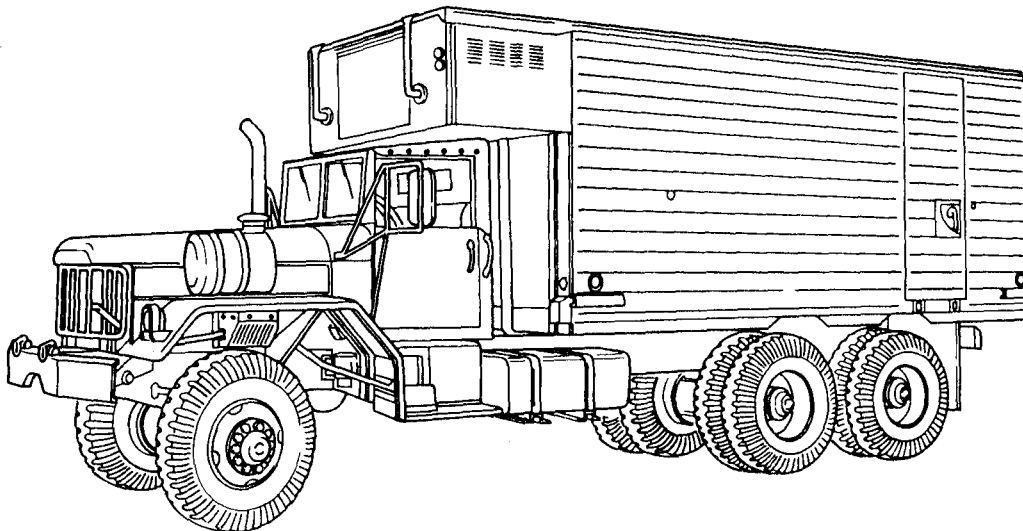

EXPANSIBLE VAN TRUCK (M820A1)

1-10. EQUIPMENT CHARACTERISTICS, CAPABILITIES, AND FEATURES (Contd)

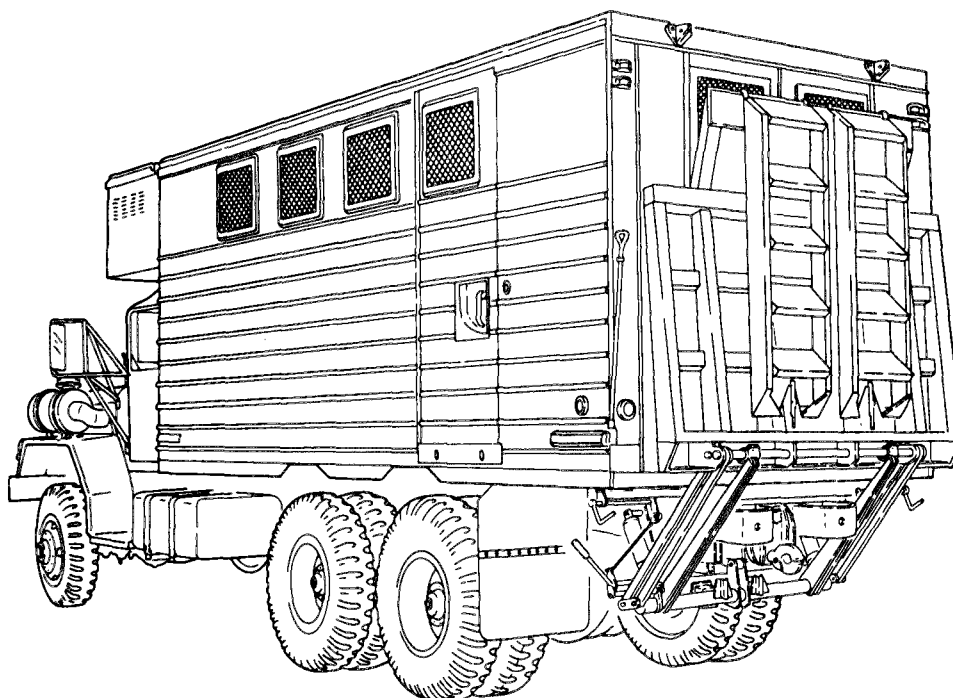

EXPANSIBLE VAN TRUCK, W/HLG (M820A2)

j. M821 Bridge Transporting Stake Truck, WO/W.

PURPOSE: This model is designed for transporting bridge building equipment and other cargo. It is equipped with a front snatch hook and rear roller for easier loading and unloading. The two hand-operated winches on the left side of the body and two winches at the rear of the body are used to secure a load on the truck.

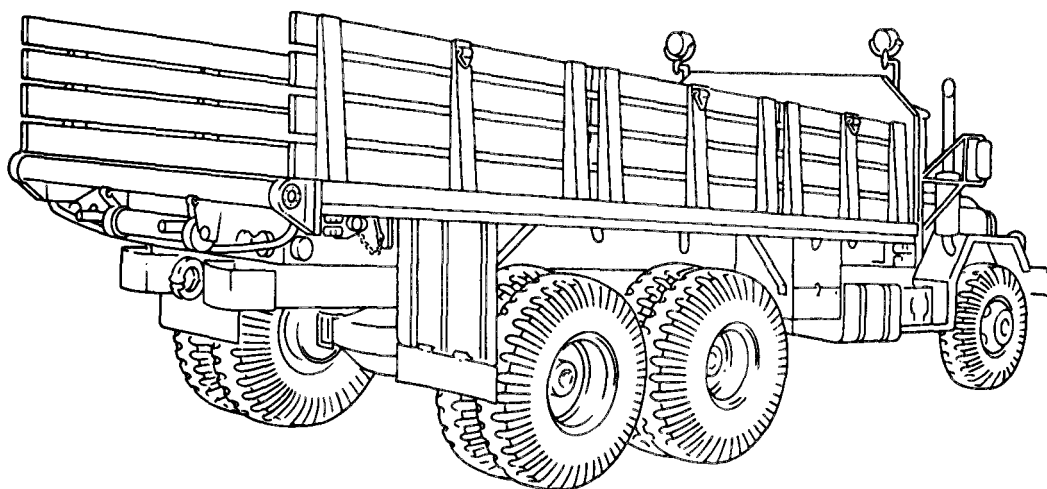

BRIDGE TRANSPORTING STAKE TRUCK (M821)

1-11. LOCATION AND DESCRIPTION OF MAJOR EXTERNAL COMPONENTS

The external components described below are common to most of the vehicles covered in this manual. Special differences can be found in TM 9-2320-260-10 or table 1-1, Differences Between Models, in this manual.

- A ENGINE** – Provides power for the vehicle.
- B LIFTING/TIEDOWN SHACKLES** – Used for lifting the vehicle during ship-to-shore operations and for tiedown attachments when transporting vehicle.
- C FRONT WINCH** – Powered by a propeller shaft extending from transmission power takeoff to permit recovery operations.
- D TRANSMISSION** – Manual transmission that transmits engine power to transfer case.
- E REAR PROPELLER SHAFT(S)** – Transmits engine power from transmission to transfer case and then to rear differentials.
- F FUEL TANK(S)** – Stores fuel.
- G REAR BOGIE** – Suspension system that supports rear vehicle weight.
- H TOWING PINTLE HOOK** – Permits towing of vehicles, trailers, and other equipment.
- I REAR DIFFERENTIALS** – Transmit power from propeller shafts through axles to wheels.
- J TRANSFER CASE** – The two-speed transfer case, along with five forward speed transmission, provides 10 speed ranges to front and rear differentials.
- K AIR RESERVOIRS** – Two storage tanks for compressed air.
- L FRONT PROPELLER SHAFT** – Transmits engine power from transfer case to front differential.
- M FUEL FILTER AND WATER SEPARATOR** – Filters contaminants from fuel.
- N AIR CLEANER** – Filters air before it enters the intake manifold.

1-11. LOCATION AND DESCRIPTION OF MAJOR EXTERNAL COMPONENTS (Contd)

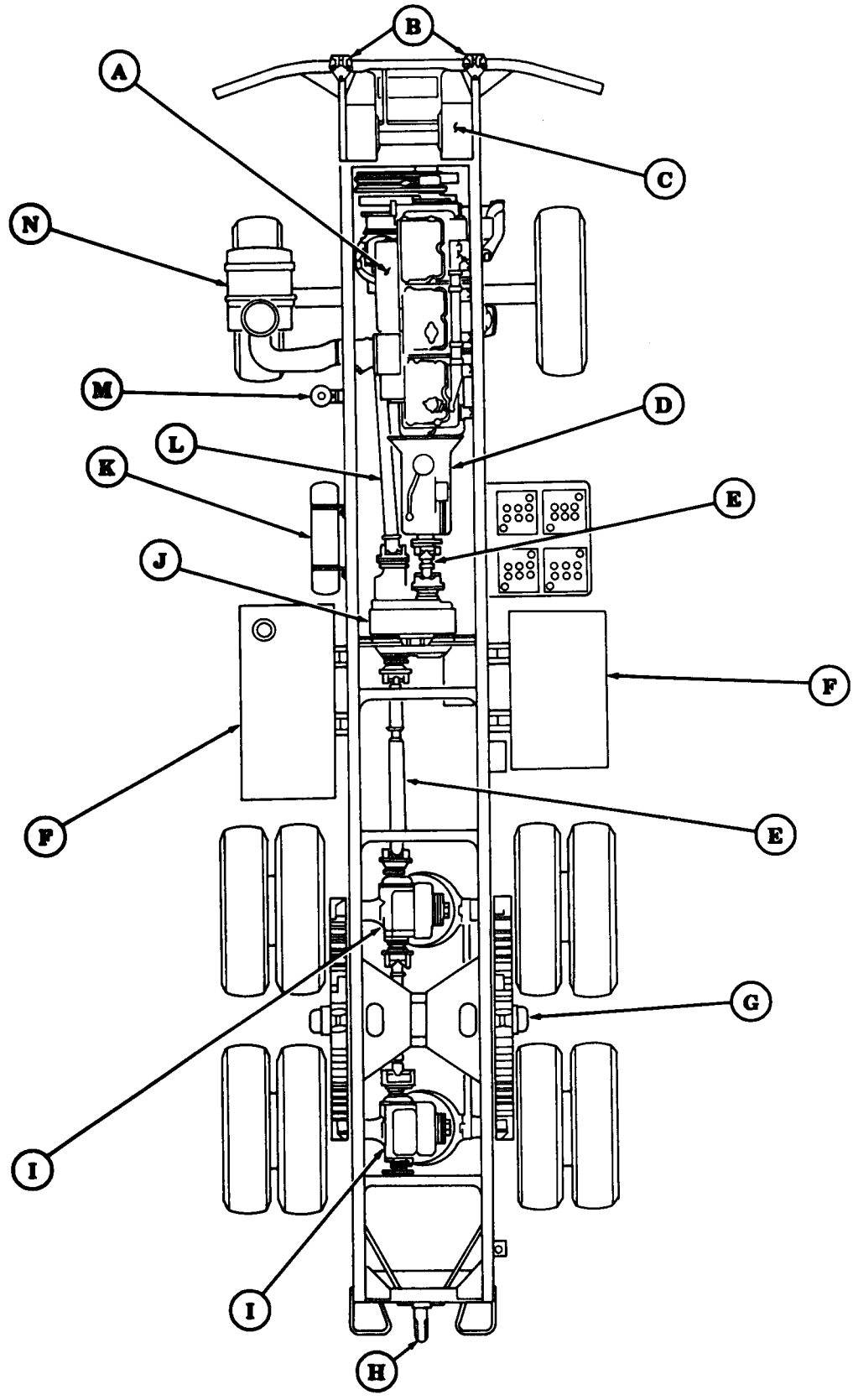

<p>1-12. LOCATION AND DESCRIPTION OF MAJOR INTERNAL COMPONENTS</p>
--

The internal components described below are common to most of the vehicles covered in this manual. Components not covered here are found in TM 9-2320-260-10 or the applicable maintenance chapters of this manual.

- A STEERING WHEEL** - Used to manually control vehicle.
- B TRANSMISSION GEARSHIFT LEVER** - Used to place transmission in 1 through 5 forward drive positions, reverse, or neutral.
- C FRONT WINCH CONTROL LEVER** - A two-position lever to engage or disengage drive to front winch.
- D TRANSFER CASE SHIFT LEVER** - Used on all vehicles to change ratio of driving power to axles and wheels. Lever is pulled up for HIGH range (greater speed and lower power) or pushed down for LOW range (lower speed and higher power).
- E DRIVER'S SEAT** - One crewmember, flotation, or fixed, adjustable.
- F POWER DIVIDER CONTROL LEVER LOCK (M816)** - Prevents power divider control lever from being placed in engaged position.
- G POWER DIVIDER CONTROL LEVER (M816)** - Used to power hydraulic crane, dump body hydraulics, and rear winch.
- H PARKING BRAKE CONTROL LEVER** - Pulled up to apply parking brake. The knob at the top of the handle is turned clockwise to increase brake cable tension.
- I HEADLIGHT BEAM SELECTOR SWITCH** - Depressed to select HIGH or LOW headlight beam.
- J ACCELERATOR PEDAL** - Used to control engine speed.
- K CLUTCH PEDAL** - Depressed to disengage engine from transmission and allows shifting to a different gear ratio.
- L BRAKE PEDAL** - Depressed to slow or stop vehicle.
- M INSTRUMENT PANEL** - Contains indicators, gages, and various switches used to monitor engine performance and activate accessory components of the vehicle.